

FIELD SERVICE MANUAL

PP 404 / PP 405

Field Service Manual PP 405/5

Uwe Panthel - PSi Customer Support

.

A Publication of Psi Matrix GmbH

Hommesswiese 116

57258 Freudenberg, Germany

<http://www.psi-matrix.eu>

Copyright © October 2018 by **PSi Matrix GmbH**

Great care has been taken to ensure that the information in this handbook is accurate and complete. Should any errors or omissions be discovered, however, or should any user wish to make suggestions for improving this handbook, he is invited to send us the relevant details.

The content of this manual are subject to change without notice.

All rights strictly reserved. Reproduction or issue to third parties in any form whatever is not permitted without written authority from the publisher.

1. Introduction

This manual is covering the two printers



- Fanfold printer
(8707-235-xxxxx)



- Multi-purpose Printer
(8707-241-xxxxx)

and it's customer specific variants.

The operation, functionality, subassemblies, and parts are mostly alike. In most illustrations, the printer with the cutter is used. In case there are differences in the Handling you will find the note:

- ***Fanfold printer***
- or
- ***Multi-purpose printer***

All the spare parts and subassemblies named here, which don't have an indication of the printer type in its name can be used for both printers.

The names of the parts, which are dedicated to one of the printers, ends with the special printer name.

The manual is divided into the following chapters:

1 Introduction

This chapter gives an overview about the manual and some basic information's.

2 Safety Precautions

This chapter contains all the important instructions a service technician should obey during a service action.

3 Keeping the Printer Running

This chapter instructs the user about preventive measures for trouble-free operation of the Printer.

4 Specific Printer Functions

This chapter describes some basic functions of the printer, which should be known by persons of the technical support staff for this product.

5 Printer Subassemblies

This chapter comprises diagrams, depicting the printer's subassemblies, The internal wiring scheme and arrangement of the collective connectors.

6 Built In Diagnostics and Trouble Shouting

This chapter gives a description of some problems and how to isolate the failures with regard to spare parts and field replaceable units concerned.

7 Procedures for Removal and Reassembly of Subassemblies and Spare Parts

This chapter contains all removal and reassembly procedures for an on- site- or workshop-repair of the printer.

8 Spare Parts Reference List

This Chapter gives an overview of spare parts and its ordernumber

9 Menu Structure PP 407 / PP 408

This Chapter shows the Menu-Tree.

10 Field Service Notes

This Chapter contains helpfull Informations of technical Steps how to.

2. Safety Precautions

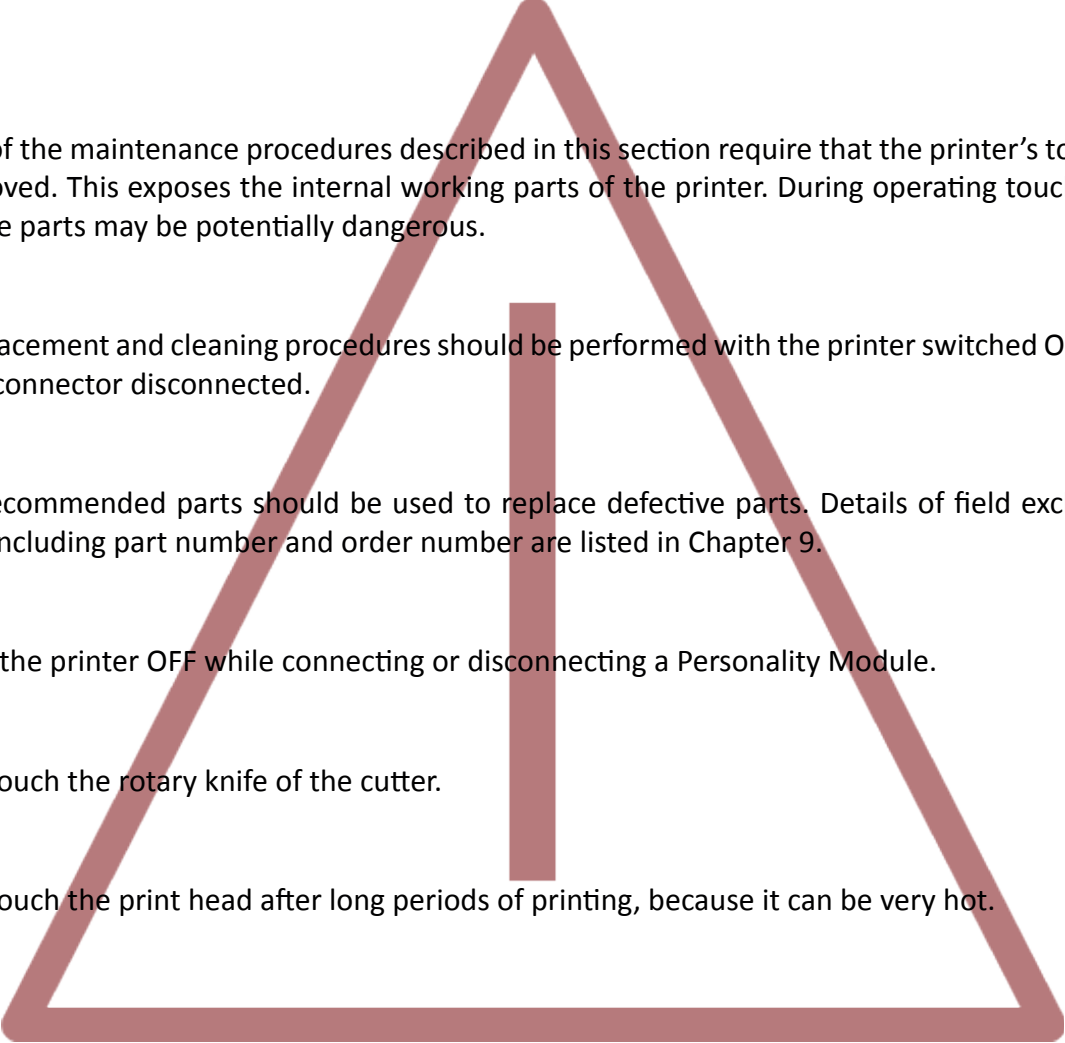
- 
- Some of the maintenance procedures described in this section require that the printer's top housing is removed. This exposes the internal working parts of the printer. During operating touching some of these parts may be potentially dangerous.
 - All replacement and cleaning procedures should be performed with the printer switched OFF and the mains connector disconnected.
 - Only recommended parts should be used to replace defective parts. Details of field exchangeable parts, including part number and order number are listed in Chapter 9.
 - Switch the printer OFF while connecting or disconnecting a Personality Module.
 - Don't touch the rotary knife of the cutter.
 - Don't touch the print head after long periods of printing, because it can be very hot.

3. Keeping the Printer Running

3.1 Basic Rules

Never print over the area of Pin holes nor the edges of the fanfold paper. Otherwise the print head can be damaged.

Never print with no paper loaded or no ribbon cartridge is installed in the printer.

Put the printer in stop mode immediately a paper ja occurs, using the  [START/STOP] key at the operator panel.

Very important:

Don't cut through labels.

Cutting through sticky labels leaves glue on the blade and on the paper guide sheets of the cutter.

This may result in blocking of the cutter module and may cause paper jam.

In addition small parts of a cut through label may detach from its paper and get stuck under the print head shield, on the platen, on top of the paper-in- sensor, on paper transport rollers, or on paper transport guides.

In case this happens yet by incident, it must be cleaned immediately. The danger is, to get hurt.

3.2 Cleaning Preferred Materials

The following materials and cleaning lubricants are recommended for use in the maintenance procedure:

- Lint-free cloth
- Platen Cleaner C/CP09, commercial no: 8709 004 10931
- Vacuum cleaner
- Silicon Oil for resolving of glue.

3.3 Cleaning the Platen and Surrounding Areas

The user should clean the printer every six months or after 50,000 prints, whichever occurs first. If you experience paper feed problems, or if the print head carriage movement becomes affected, cleaning should be carried out more often.

Note: the Page Counter (PGCNT) in the PRINT-TEST 3 will give you information about actual number of printed pages. See sample next page.

CONFIGURATION

FW	20815776	F-D	0.2	F-X	0.3	PM	00-013665-0
NFQ	1500	DSF	100	NLSF	100	LSF	100
GSF	80	NFT	270	TNA1	230	TNA2	260
TNA3	260	CAC	2.60	NDLC	2.2	PGC	46
PGCNT	143299	SBP	36				

C031 ISO 8859/1	C032 ISO 8859/15	C034 ISO 8859/5
C032 ISO 8859/9	C061 IBM SET 1	C062 IBM SET 2
C063 IBM CODE PAGE	C071 EPSON EXT. GCT	C100 CODE PAGE EE
C101 CODE PAGE EE2	C912 GREEK CHR. SET	C069 ALL ICT TABLE
C091 BARCODE		
DATA	ROMAN NLQ	ROMAN LQ
SANS SERIF NLQ	SANS SERIF LQ	COURIER NLQ
COURIER LQ	PRESTIGE NLQ	PRESTIGE LQ
SCRIPT NLQ	SCRIPT LQ	OCR B LQ
OCR A LQ	ORATOR-C NLQ	ORATOR-C LQ
ORATOR NLQ	ORATOR LQ	DATA LARGE

CHARACTER SET : EPSON EXT. GCT 1: U.S.A.



ect.

3.3.1 Cleaning Procedure

- Power the printer ON and remove the top cover.
- Remove the ribbon cassette.
- Power the printer OFF.
- Thoroughly brush and vacuum all accessible areas to remove any paper flock and dust.
- Clean the platen's surface, the paper pressure rollers and the transport rollers using the platen cleaner. In order to access the transport rollers loosen the green screws and remove the metal bar with the metal rollers.
- Clean the covers and the operator panel with a damp, lint-free cloth. Do not use cleaning solvents or excessive amounts of water.
- Insert the ribbon cassette.
- Remount the top cover.

Note: Cutting through labels is not allowed. But if it has happened yet, thoroughly remove all the glue from the blade and the paper feeding guides in the cutter.
For dissolving use lubricants like silicon oil.

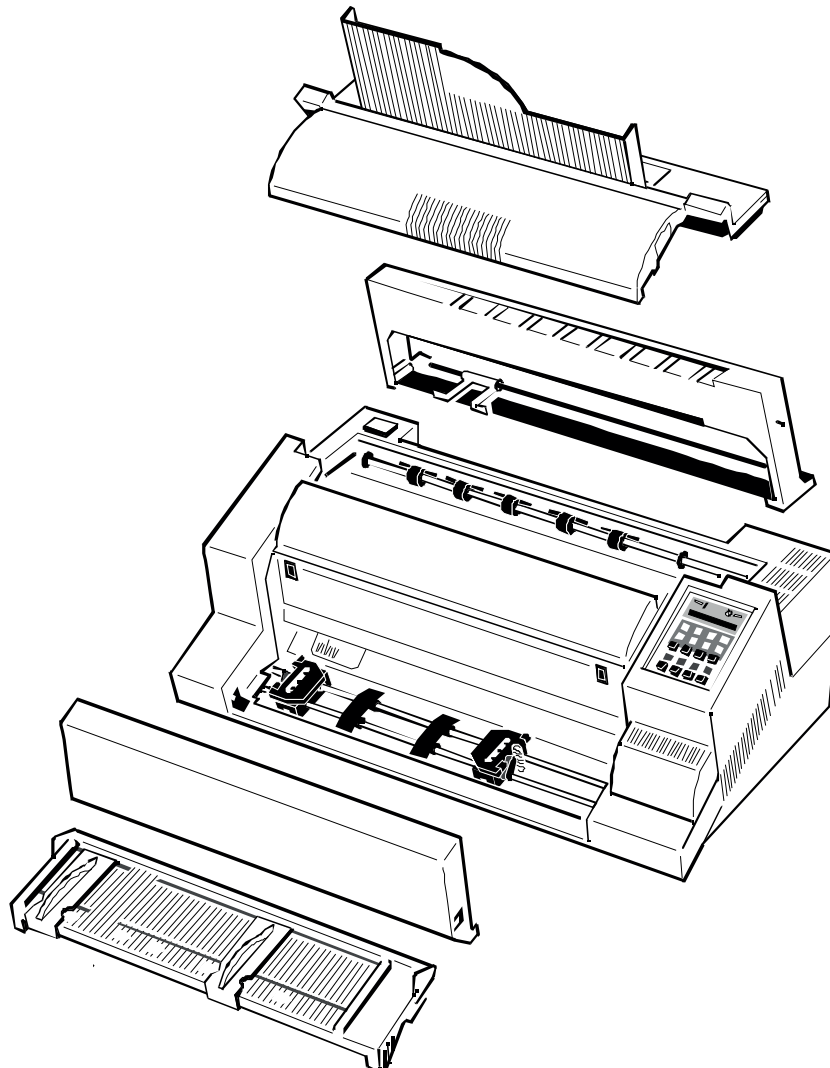

3.4 Status and Error Messages during Operating

The following messages are displayed if a condition exists which prevents normal operation of the printer.

LOCAL

Entered when was pressed. The STOP indicator is lit.

COVER OPEN

Displayed when the top cover is open and the printer is in the READY or BUSY mode.

LOAD TRACTOR

Displayed when the host sends a form feed or print command to an empty tractor cassette. The printer enters the STOP mode.

LOAD MANUAL

Same as LOAD TRACTOR except that the machine does **not** enter the **STOP** mode! Paper should be feed

PAPER JAM TRFP,APER JAM ASF, PAPER JAM MANUAL

Displayed if a form jams in the ASF (*only for Multi-purpose Printer*) or if successive line feeds fail to move fanfold paper correctly when tractor feed is used.

TEAR OFF PAPER

Displayed when a switch has been initiated from currently tractor to a different paper source and the fanfold paper could not retreat into the parking position. The operator must „tear off“ the paper along the tear off edge which is located directly above the fanfold paper output (paper should be torn off from left to right). Press  to enable the fanfold paper to be fed backwards to a park position so that the newly selected paper source can be used.

REMOVE PAPER

This message will be displayed if the output for cut sheets (Bin or Manual) is selected to **FRONT SIDE/KEY**. After printing and moving out at the front side the printer enters the STOP mode and displays **REMOVE PAPER**. Remove paper and press .

During operation the following error messages may also occur:

Display	Meaning	Cause
AGC ERROR	AGC ADJUST procedure fault	<ul style="list-style-type: none"> Distance print head and platen faulty Print head loose Platen incorrectly installed Ribbon not inserted Horizontal drive without function Platen got dirty
HORIZ. DRIVE ERROR	Horizontal drive without function	<ul style="list-style-type: none"> Horizontal drive blocked Paper jam Distance of platen gap too narrow AGC procedure not in workable position Platen incorrectly installed No AGC ADJUST after print head or platen replacement Device electronic faulty Encoder strip missing Horizontal drive faulty
PARITY ERROR	Protocol error	<ul style="list-style-type: none"> Check protocol setting of printer and host
BUFFER OVERFLOW		
FORMAT ERROR		
FRAMMING ERROR		

For other messages refer to Section **6.2 Error Messages during Power Up**.

4. Specific Printer Functions

4.1 Print Gap Adjustment

Principle

The print head carriage is mounted on two parallel guide rails, which provide for a precise movement over the completely print range in horizontal direction. The lower rail is built up as an eccentric shaft. The eccentric arrangement is driven by a stepper motor (AGC-Motor). Those both elements are responsible for the precise adjustment of the print gap, which is the distance between the print head top and the paper respectively the platen assembly.

In conjunction with print gap adjustment, the following three different procedures have to be distinguished:

Calibration of the print gap adjustment mechanics, called Automatic Gap Control Adjustment (AGC Adjust)

Automatic print gap adjustment, called Automatic Gap Control (AGC)

Programmed print gap adjustment, called Programmed Copy Control (PCC) AGC Adjust and AGC are performed by means of the AGC Procedure. AGC Adjust can be called up via the operator panel and is performed after installation of a Personality Module with a new firmware revision.

AGC is automatically performed after changing from online - offline – online, and after changing of the paper path.

PCC is performed if the command PCC is sent to the printer. For reference see “Quick Reference” of the printer control commands in the appendix of the user manual.

4.2 AGC Procedure

At the start the print head/carriage is horizontally positioned at the AGC Position

The carriage is permanently moved in horizontal direction by a distance of 1/120" to the left and right hand side of the AGC Position.

The time period for horizontal movement is permanently recognized by

The firmware and checked against a reference value.

Simultaneously to the above shuttling the print head / carriage is moved towards the platen assembly by means of the AGC drive until the print head top gets in contact with the platen assembly or the surface of the paper.

The contact of the print head top with the surface of the paper or the platen assembly is recognized by the firmware by checking the time

Interval for positioning within the shuttling process.

Note: Horizontal Drive Error will not be checked by this procedure. If the movement of the print head is to hard the printer use 0.5 a more.

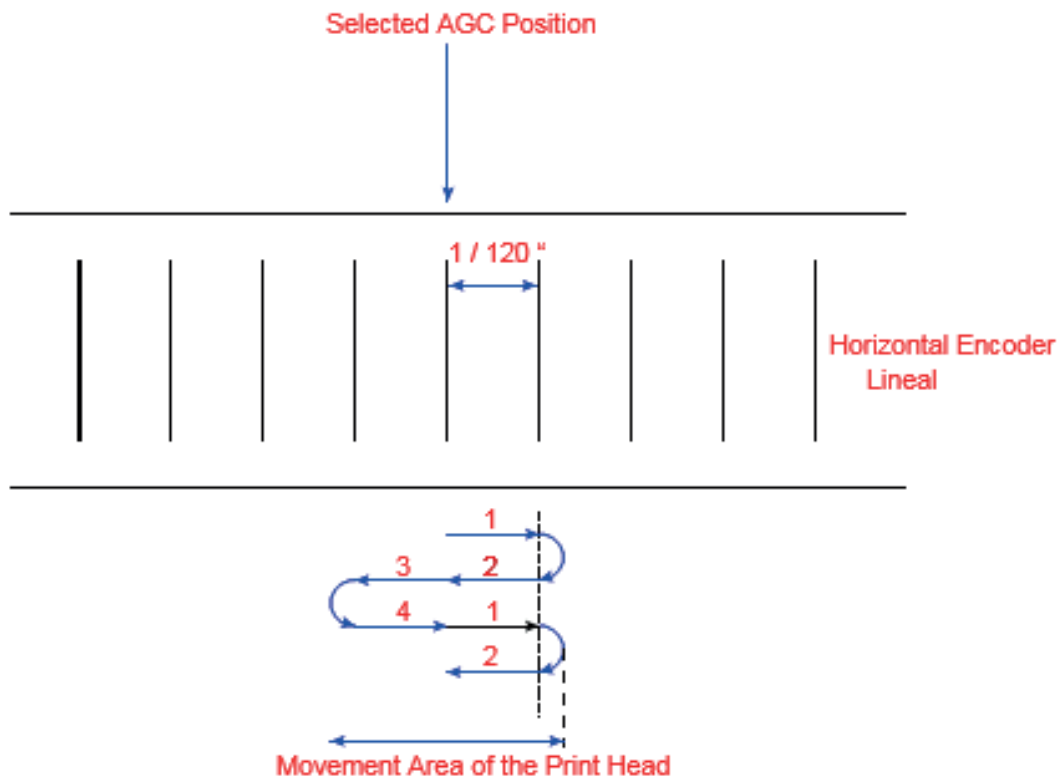

4.3 AGC Adjust

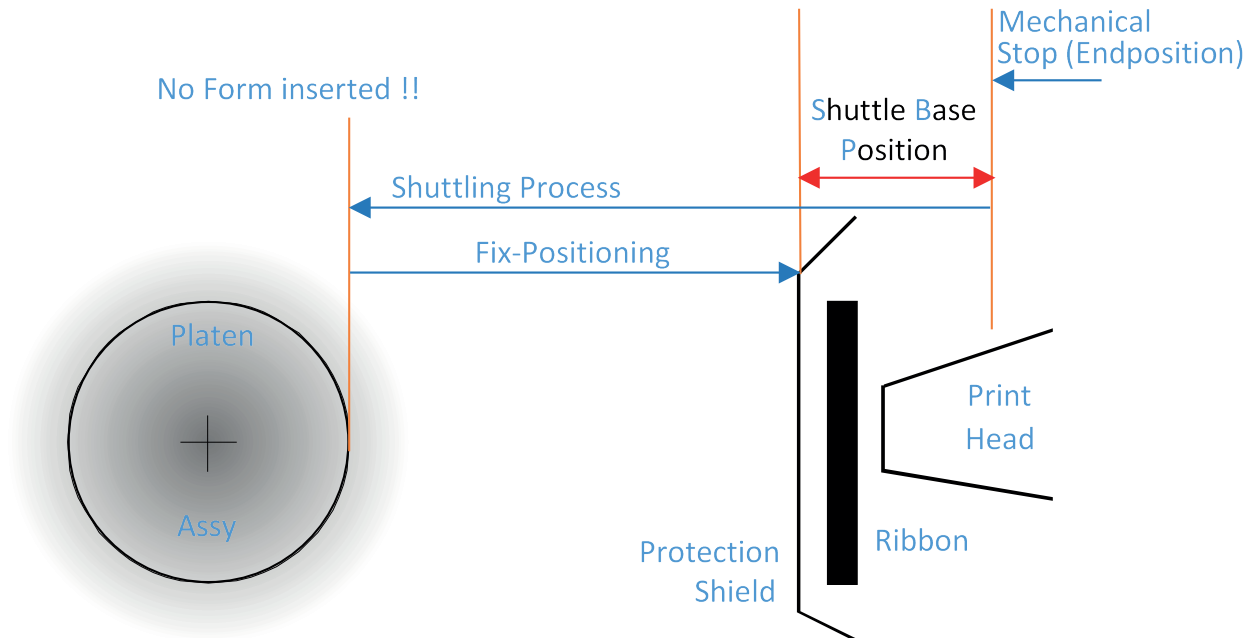

- The print head/carriage is positioned at the AGC Position
- The AGC procedure is started. It can be started from any value of the print gap.
- The print head/carriage is positioned against the mechanical stop
- As soon as the mechanical stop has been reached the so called "AGC procedure" is started
- After finishing the AGC Procedure the carriage is positioned according to the Shuttle Basis Position (see SBP in Print Test 3).

Note: No form, but ribbon to be inserted.
Tolerance range for SBP: -12 ... +72.

4.4 Automatic Gap Control (AGC)

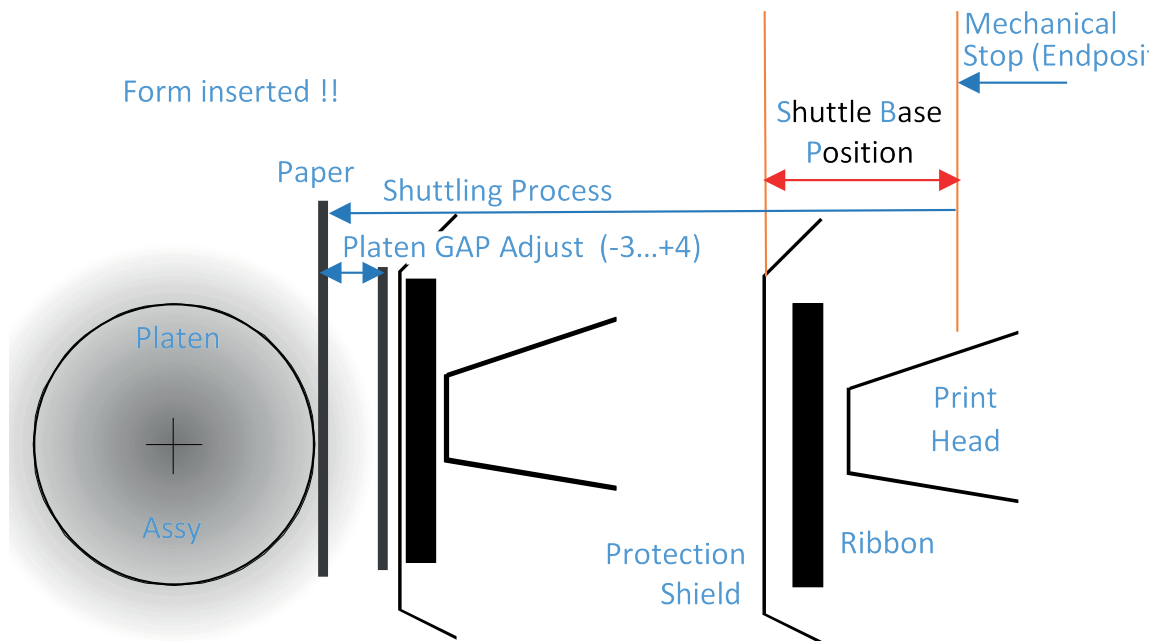

- AGC can be started from any value of the print gap.
 - The print head/carriage is positioned at the Shuttle Basis Position
 - As soon as the SBP has been reached, the so called “AGC Procedure” is started
- After finishing the shuttling process the carriage is positioned according to the proper print gap value.

4.5 Programmed Copy Control (PCC)

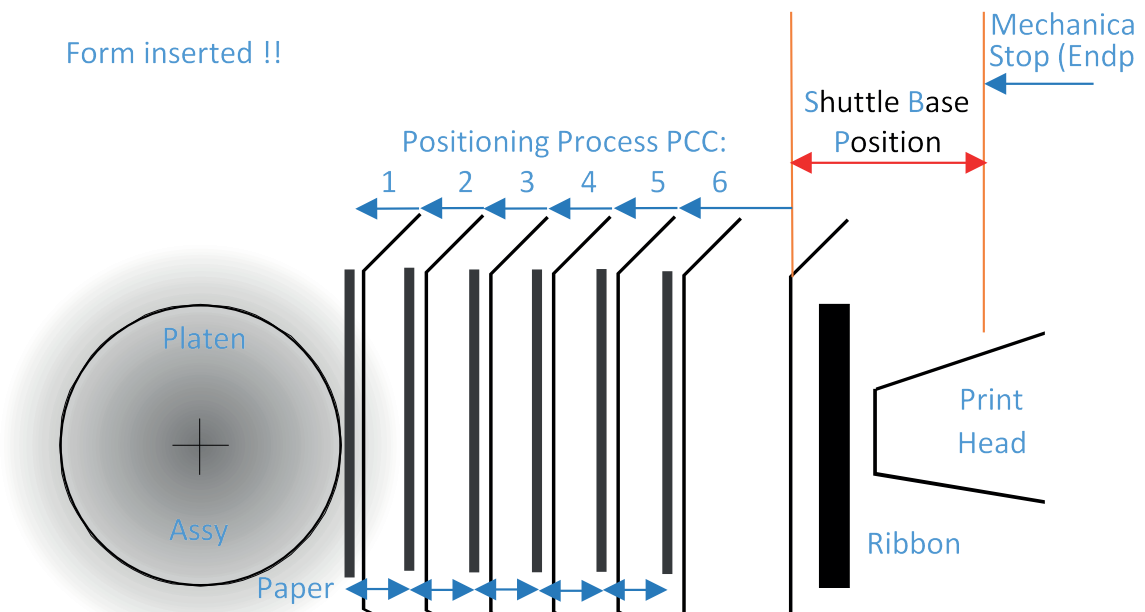

- The print gap is set according to the value commanded by the PCC command.

4.6 Print Head - Tilting Principle

- The nose of the print head can be tilted according to the scheme above.
- The different tilting positions are used for realizing of the different print modes and therefore different print speeds and print resolutions.
- Switching between both print head tilting positions is accomplished by positioning of the carriage to be the most right hand side position.

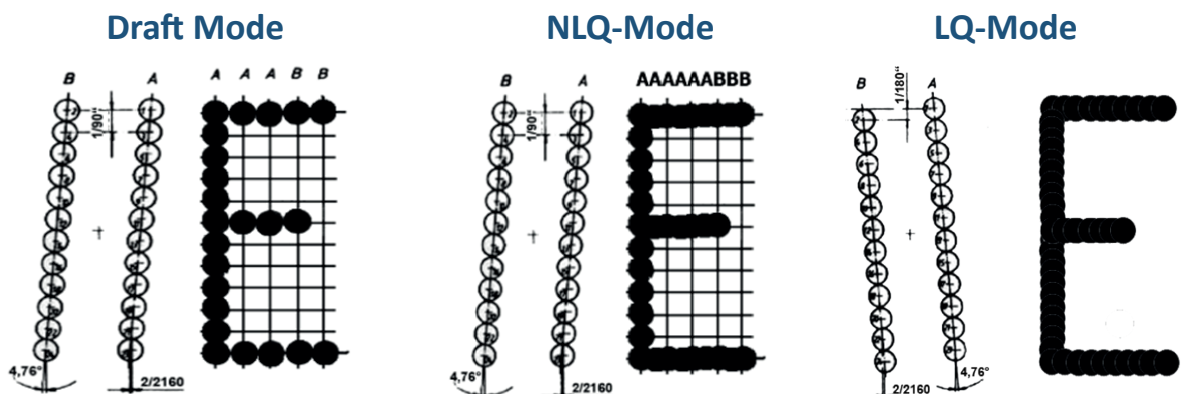
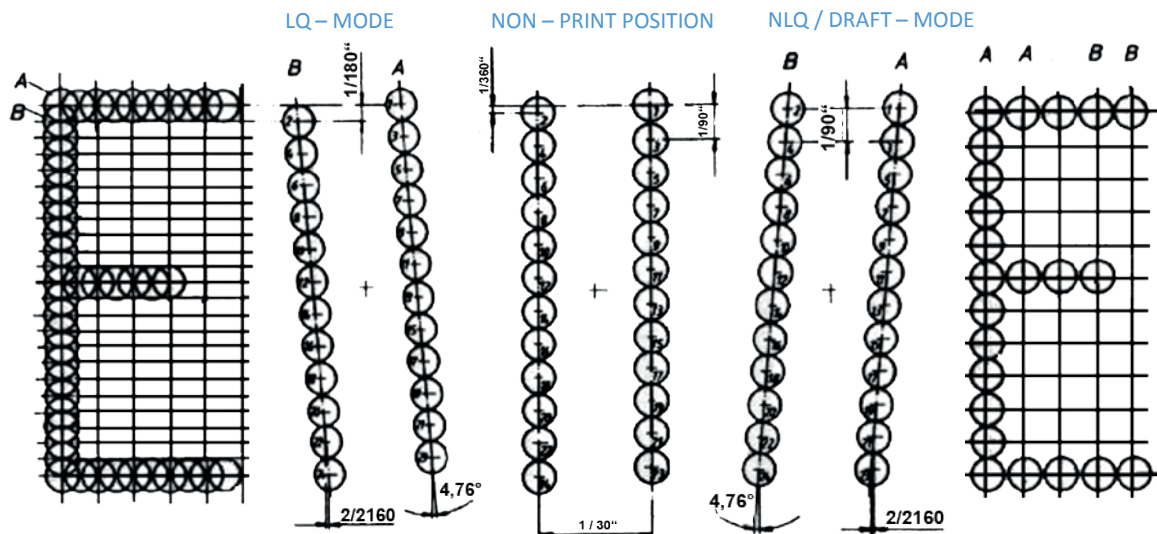
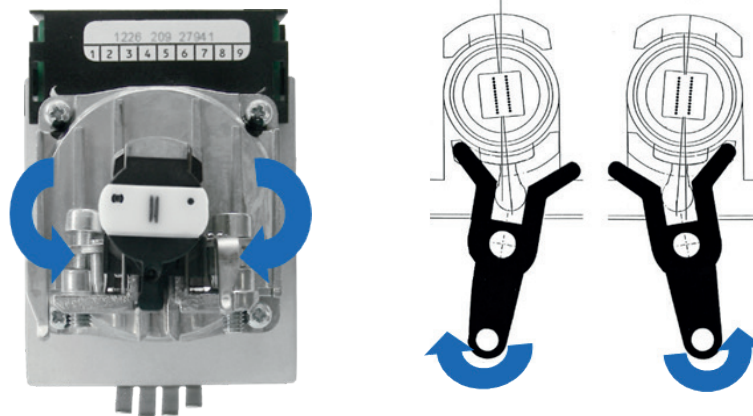

4.7 Printing Speeds

4.7.1 Printing Speed in DATA mode

Inclination Position

Needle frequency **1.800 Hz^(M)** **1.500 Hz^(F)** of the Print Head Lug

Number of columns per character: 12, 2x 12 needles in use Number of needles per character: 3, each other needle activated

- = needle activated
- = needle not activated

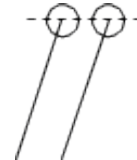

1	2	3	4	5	6	7	8	9	10	11	12
●	○	●	○	●	○	●	○	●	○	●	○

$$\text{Print Speed} = \frac{\text{needle strokes per second}}{\text{number of needles per Character}} = \frac{1800/1500}{3} = 600/500 \text{ cps}$$

4.7.2 Printing Speed in NLQ mode

Inclination Position

Needle frequency **1.800 Hz^(M)** **1.500 Hz^(F)** of the Print Head Lug

Number of columns per character: 36, 2x 12 needles in use Number of needles per character: 6, each 3rd needle activated

- = needle activated
- = needle not activated

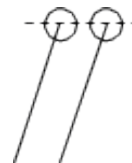

1	2	3	4	5	6	34	35	36
●	○	○	●	○	○	●	○	○	●	○	○

$$\text{Print Speed} = \frac{\text{needle strokes per second}}{\text{number of needles per Character}} = \frac{1800/1500}{6} = 300/250 \text{ cps}$$

4.7.3 Printing Speed in LQ mode 1 ¹⁾

Inclination Position

Needle frequency **1.800 Hz^(M) 1.500 Hz^(F)** of the Print Head Lug

Number of columns per character: 36

Number of needles per character: 12, each 3rd needle activated

- = needle activated
- = needle not activated

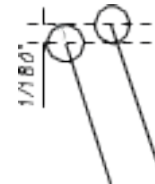

1	2	3	4	5	6	34	35	36
●	○	○	●	○	○	●	○	○	●	○	○

$$\text{Print Speed} = \frac{\text{needle strokes per second}}{\text{number of needles per Character}} = \frac{1800/1500}{12} = 150/125 \text{ cps}$$

4.7.4 Printing Speed in LQ mode 2 ¹⁾

Inclination Position

Needle frequency **1.800 Hz^(M) 1.500 Hz^(F)** of the Print Head Lug

Number of columns per character: 36

Number of needles per character: 18, each other needle activated

- = needle activated
- = needle not activated

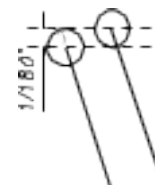

1	2	3	4	5	6	34	35	36
●	○	●	○	●	○	●	○	●	○	●	○

$$\text{Print Speed} = \frac{\text{needle strokes per second}}{\text{number of needles per Character}} = \frac{1800/1500}{18} = 100/83 \text{ cps}$$

¹⁾ Depending on the selected font ^{M)} Multi-purpose printer ^{F)} Fanfold printer

4.8 Positioning System-Horizontal Positioner

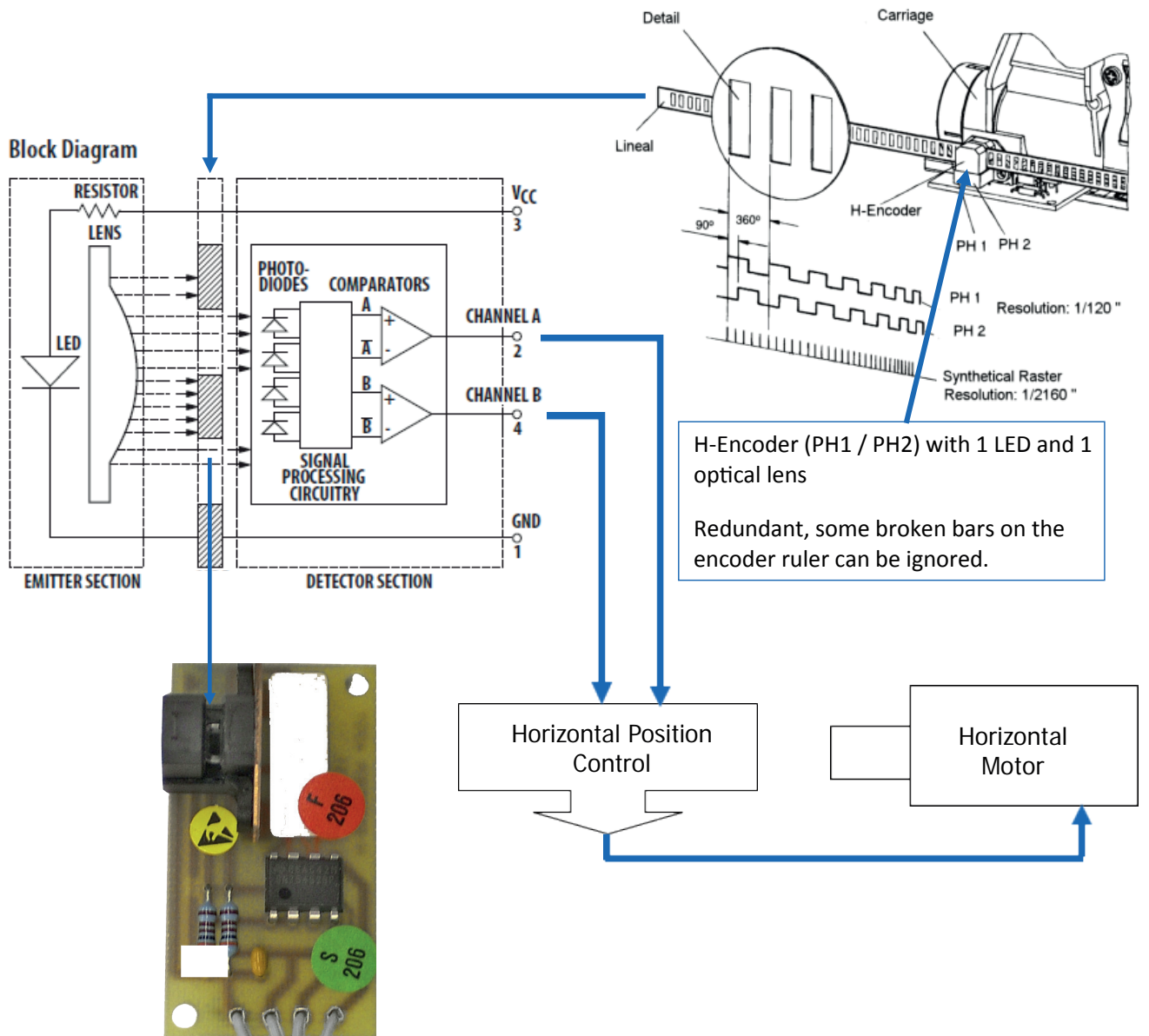

4.9 Paper Path

4.9.1 Paper Transportation Principle - Multi-Purpose Printer

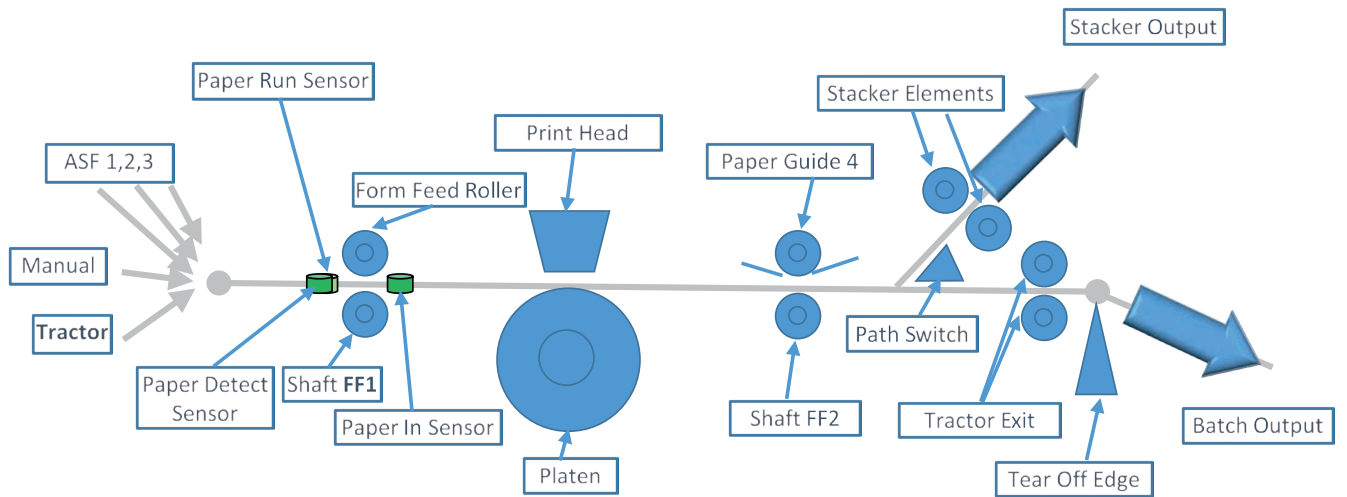
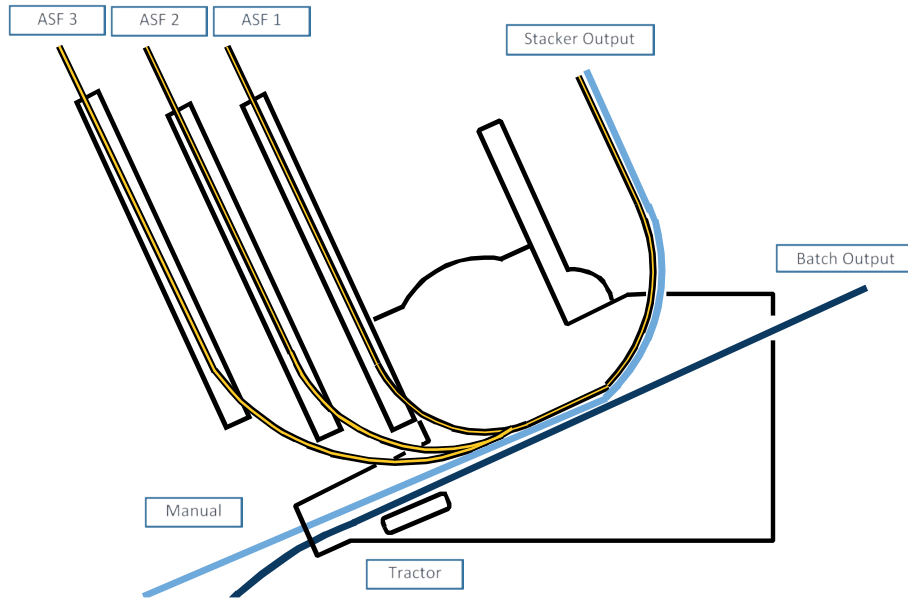

4.9.2 Paper Transportation Principle - Multi-Purpose Printer

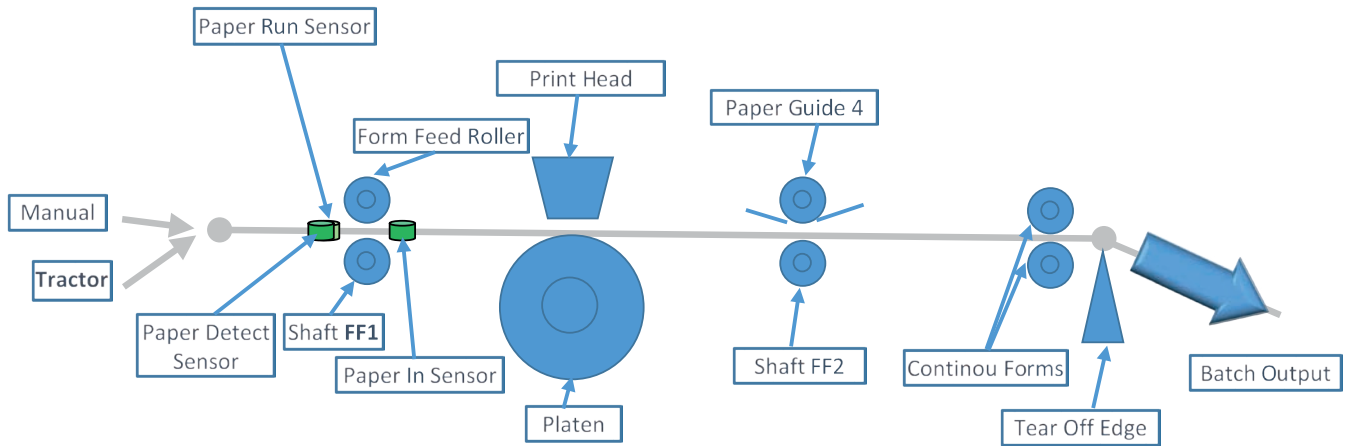
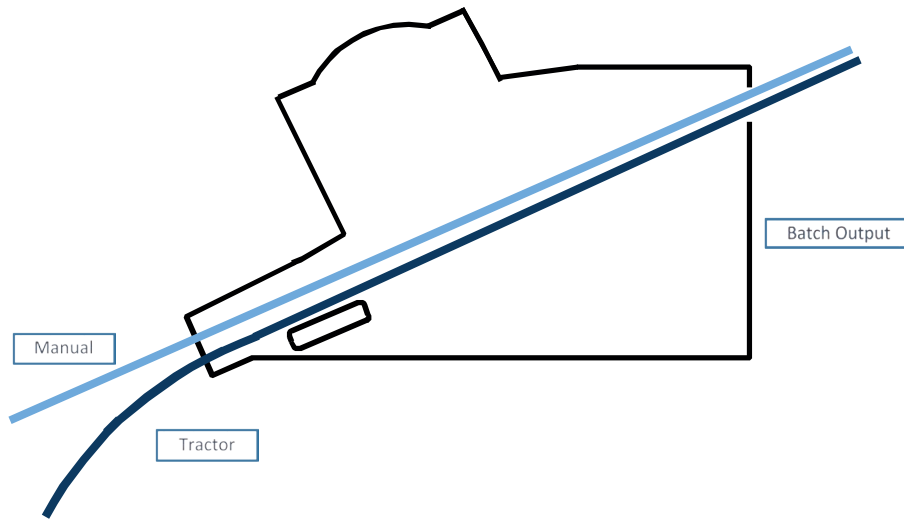

4.10 Basic Elements of the Printer

4.10.1 Multipurpose Printer

- | | |
|---------------------|-------------------------------------|
| Top cover (1) | Power cord socket (6) |
| Ribbon cassette (2) | Control panel (7) |
| Printer base (3) | Interface serial, parallel, USB (8) |
| Stacker (4) | Tear off edge (9) |
| Power switch(5) | Front cover(10) |
| | Manual Front Insert (11) |

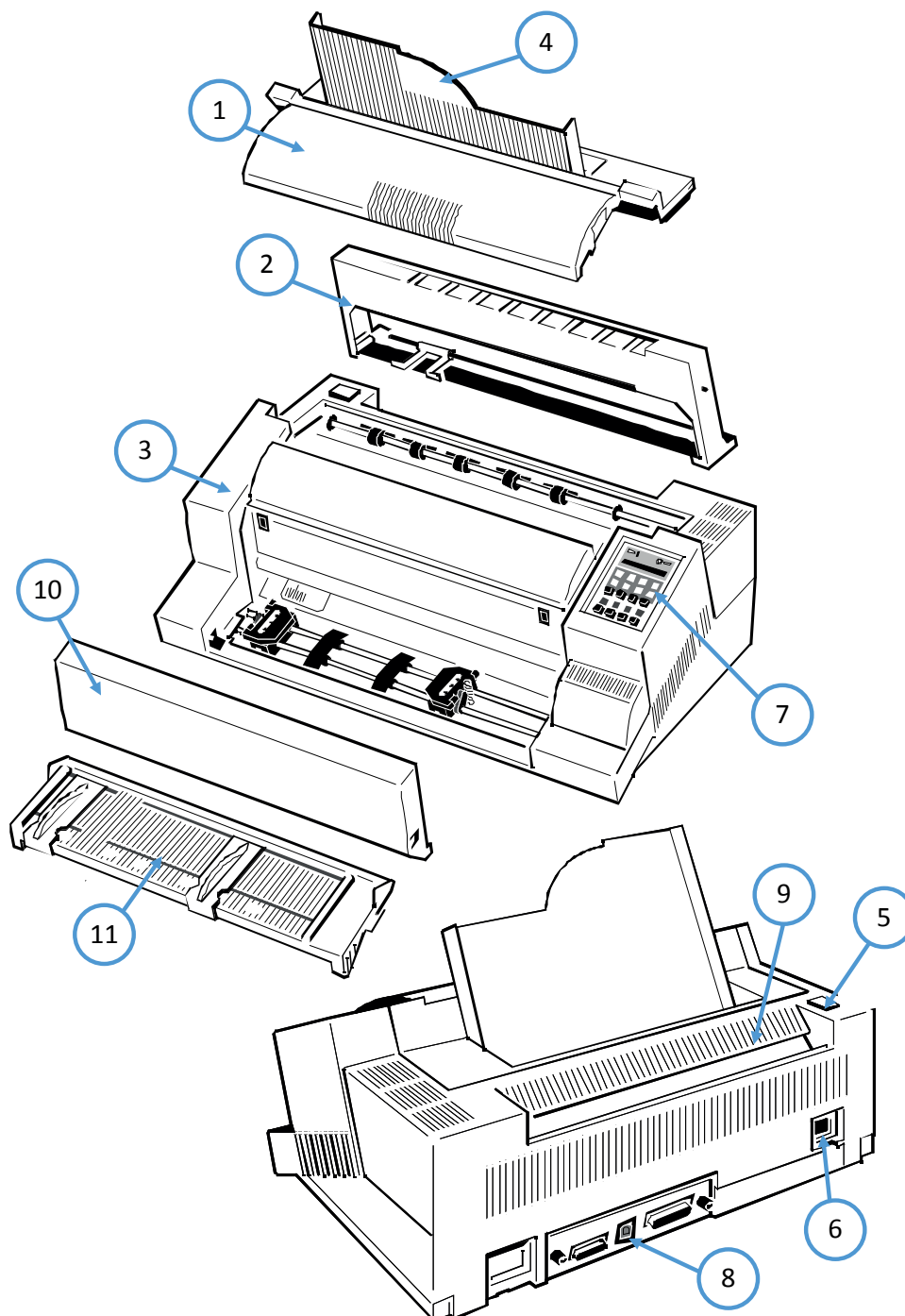

4.10.2 Fanfold Printer

- Top cover (1)
- Ribbon cassette (2)
- Printer base (3)
- Front Cover (4)
- Power switch(5)

- Power cord socket (6)
- Control panel (7)
- Interface serial, parallel, USB (8)
- Tear off edge (9)

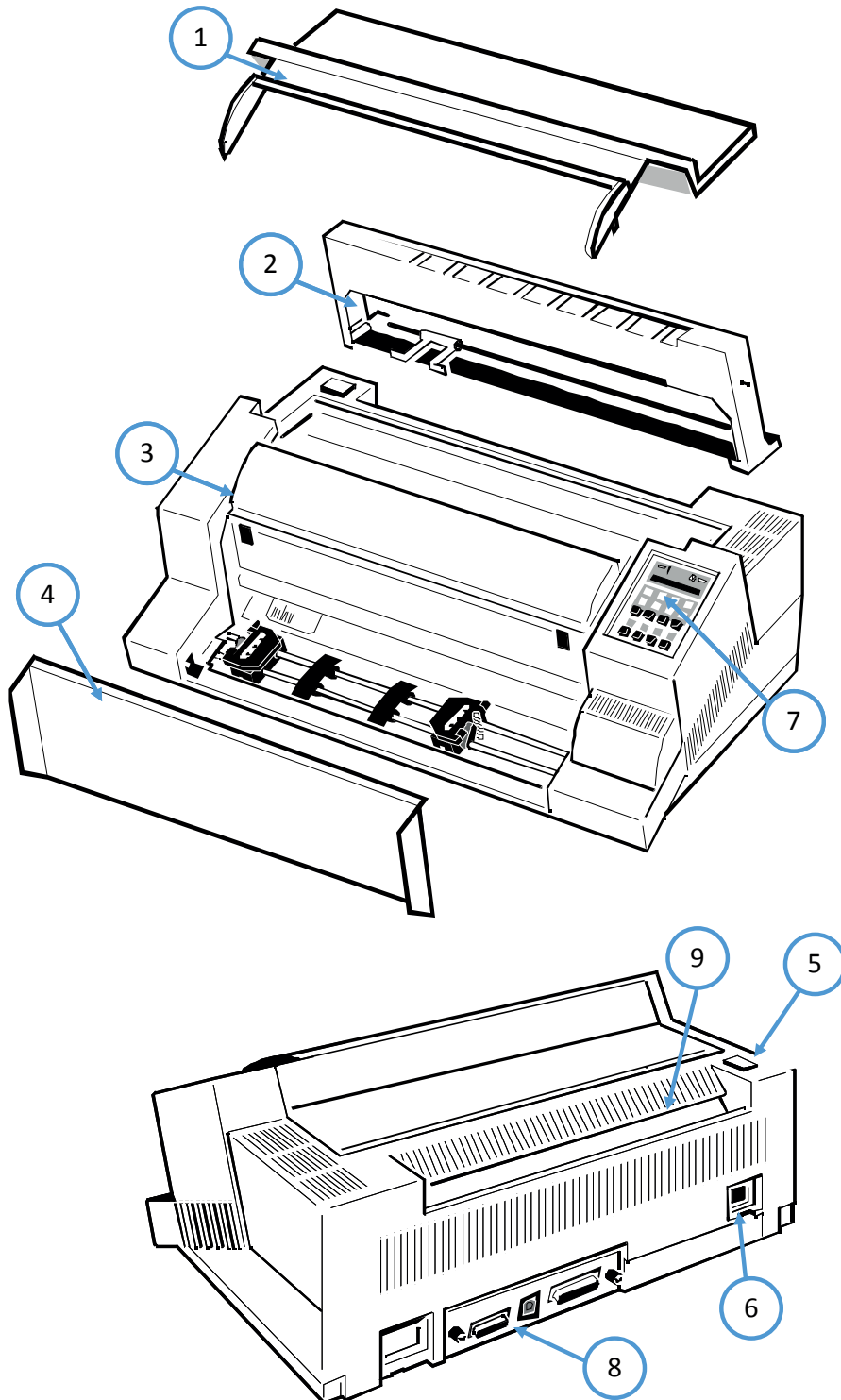

4.11 Main Subassemblies

The main subassemblies are:

- Mechanical assembly Fanfold Printer (1)
- Mechanical assembly Fanfold Printer (2)
- Electronic assembly (3)
- Interface Module (PM) (4)

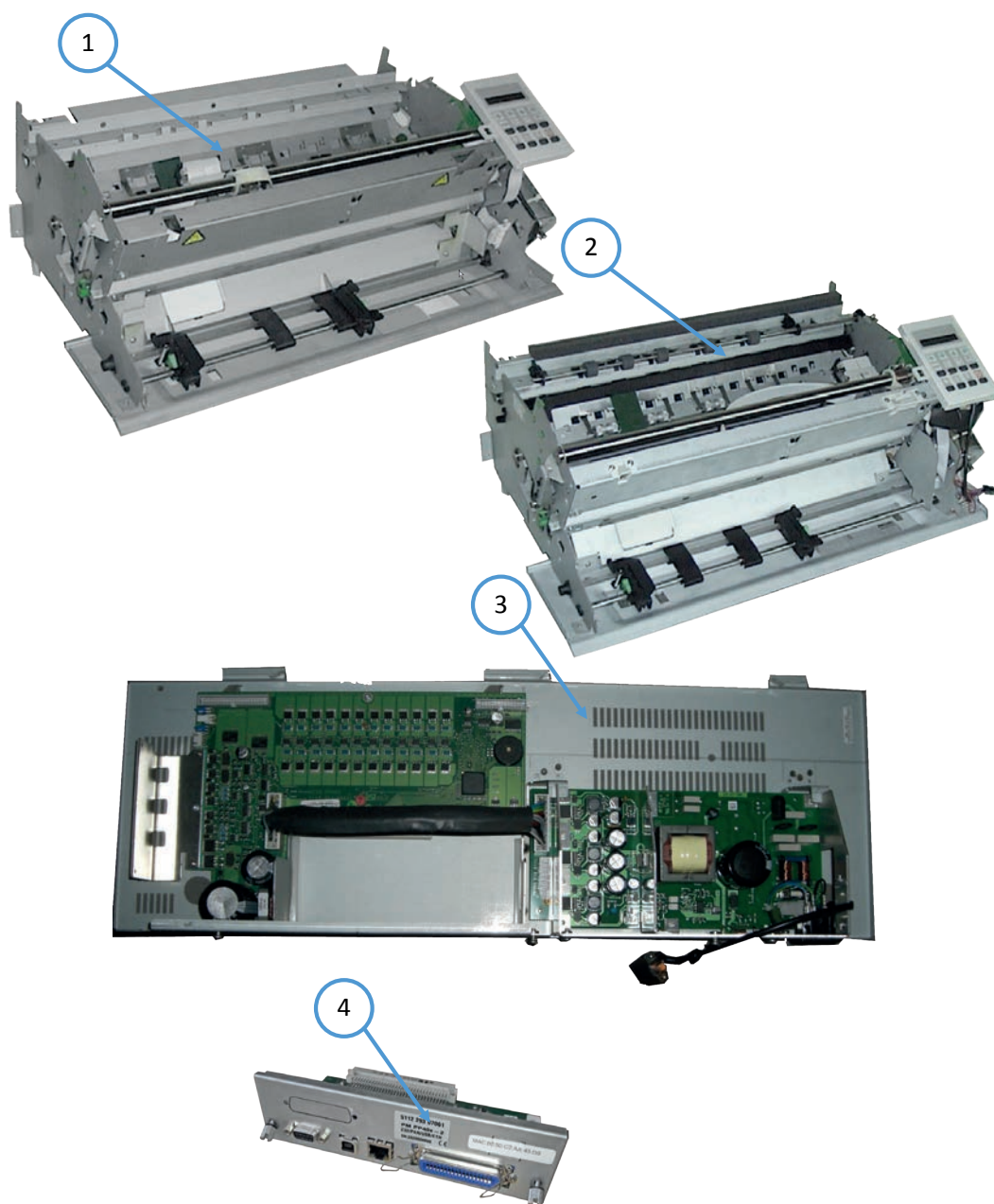

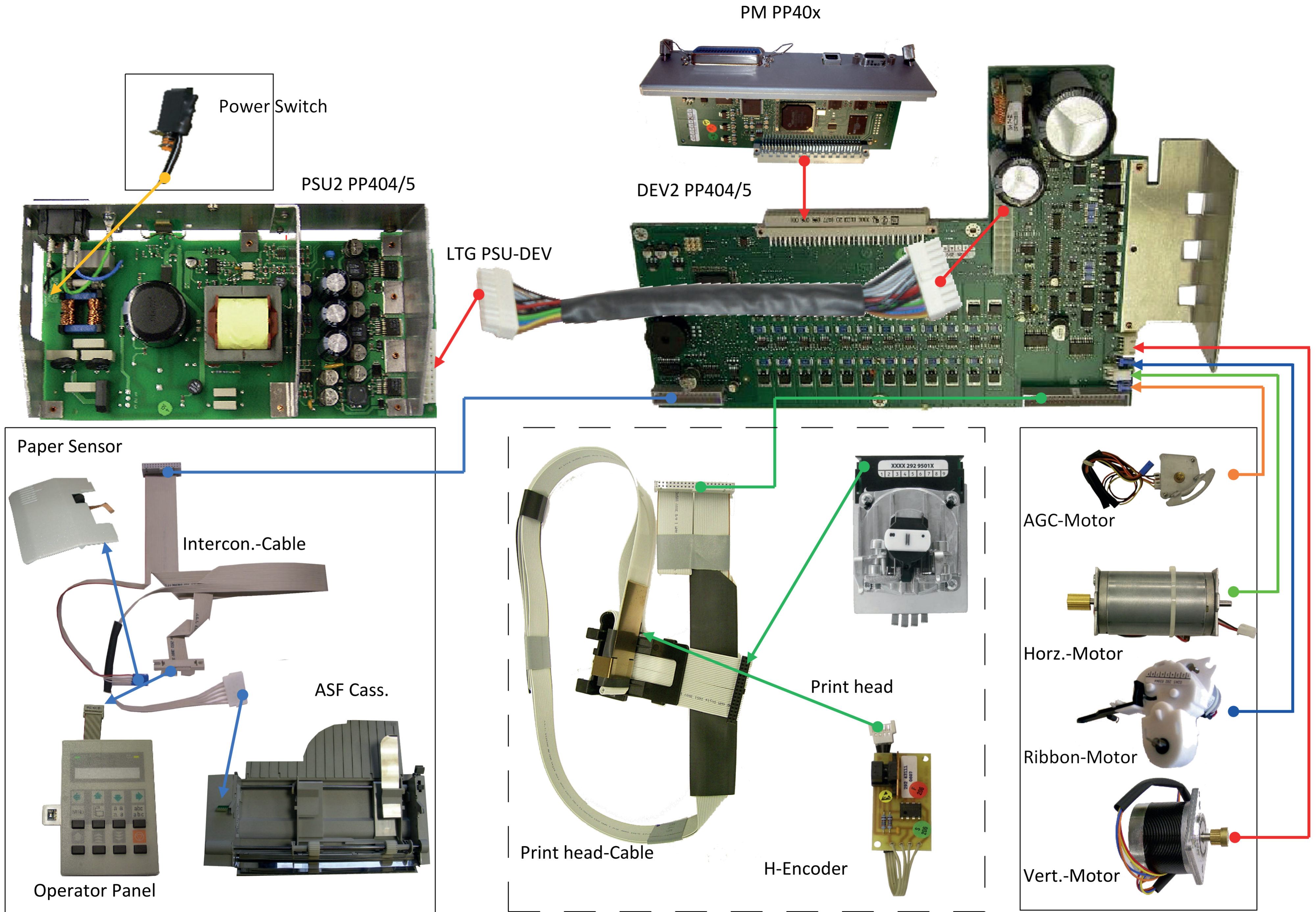

5. Built In Diagnostics and Trouble Shooting

How to Use This Section

- Find the category in which your problem occurs. The problem categories are:
- Power-related Problems
- Error Messages
- No Printout
- Operation-related Problems
- Print-related Problems
- Paper Jam
- Ribbon or Carriage-related Problems

For example, if the print appears very light on the paper, look at Section Print- related Problems.

- Find the symptom description that most closely matches the printer symptom. In this example you would look at the symptom „Print faint or of poor quality.“
- Try the first suggestion under that heading.
- If the suggestion does not cure the problem, try the next suggestion.
- If none of the suggestions enable you to continue printing, or if the fault is not listed, contact your service.

Each time when the printer is switched “ON” the display indicates TEST while the internal self-tests are run. If the test is completed successfully “READY 4 ELQ” will be displayed. If an error message is displayed please refer to the section 6.2 Error Messages during Power Up. All other messages on the display are described in section 6.2 Status and Error Messages during Operation.

5.1 Power- related Problems

Power indicator does not come On when power is switched On

- Check that the power cord and plug are securely fitted to the printer and to an electrical outlet.
- Ask for the power connector connections (and fuse, if fitted) to be verified.
- Ask for the building electrical supply to be verified.

5.1.1 Error Messages during Power Up

After switching the power ON the printer runs a self-test. During the test the following messages may be shown on the display:



Display	That means ...	Cause / Action
No information, POWER ON Indicator not lit.	No power	<ul style="list-style-type: none"> • Mains cable not connected • Mains switch cable not connected
green and yellow LED give light but no reaction	hang up in reset after power on	<ul style="list-style-type: none"> • Print PSU2 defective • Print DEV2 defective
#####	Firmware does not work	<ul style="list-style-type: none"> • PM not inserted • PM not correctly inserted • no firmware on PM
TEST.... (flashing)	Initializing of the EEPROM	<ul style="list-style-type: none"> • After first POWER ON with new firmware (different code number) • Contents of the EEPROM faulty • PM installed into another printer type
I/O OK	EEPROM located on the Port addressable	<ul style="list-style-type: none"> • EEPROM- defective (DEV2)
Waiting for Data	No firmware available	<ul style="list-style-type: none"> • Download a new firmware



If all tests have been passed successfully the following message will be displayed:

Display	That means ...	Cause / Action
READY/BUSY	The Printer is OK	<ul style="list-style-type: none"> • Printer ready for operation

5.1.2 Messages during normal operation

The following error messages may occur (for further operator panel messages please refer to Status and Error Messages):

Display	That means ...	Cause / Action
AGC ERROR	AGC ADJUST procedure fault	<ul style="list-style-type: none"> • Distance print head and platen faulty • Print head loose • Platen incorrectly installed • Ribbon not inserted • Horizontal drive without function • Platen got dirty
HOR. DRIVE ERROR	Horizontal drive without function	<ul style="list-style-type: none"> • Transport lock not removed • Horizontal drive blocked • Paper jam • Distance of platen gap too narrow • AGC procedure on not workable position • Platen incorrectly installed • No AGC ADJUST after print head or platen replacement • Device electronic fault • Encoder strip missing • Horizontal drive fault
STOP	The printer is in STOP mode	<ul style="list-style-type: none"> •  Press to continue
COVER OPEN	Top cover is open and the printer is in READY or BUSY mode	<ul style="list-style-type: none"> • Close the cover and press to continue
LOAD TRACTOR LOWER / UPPER	Displayed when the host computer issues a paper feed or print command and no paper is left. The printer switches to STOP mode.	<ul style="list-style-type: none"> • Insert paper and press 
PAPER JAM TRF	Displayed if the continuous paper is not transported correctly when using the tractor feeder with successive line feeds.	<ul style="list-style-type: none"> • for troubleshooting see section Operating Problems and section Error Diagrams.

Display	That means ...	Cause / Action
PAP. TEAR OFF	Appears when switching from the current paper source to another paper source and the continuous paper could not be moved to the park position. The continuous paper must be torn off along the back edge of the printer, which is directly above the continuous paper exit (from left to right).	<ul style="list-style-type: none"> press  the paper is moved back to the park position so that the newly selected paper source can be used.
REMOVE PAPER	Displayed when switching from the currently selected tractor to another paper source, where the continuous paper could not be moved to the park position. The continuous paper must be torn along the back edge of the printer, which is just above the rear paper exit and torn off (from left to right).	<ul style="list-style-type: none"> Remove Paper and press 

5.2 No Print out

Test print out does not start.

- Check, that all covers has been closed.
- Check, that paper is loaded in the printer.

5.2.1 Printing does not start

- Make sure that the READY or BUSY message is displayed. If there is a different message displayed please refer to the above error message table.
- Make sure that the printer is connected to the host computer. (Refer to section 1.13 Connection to a Computer). Make sure that connectors are properly fixed at both ends.
- Make sure that the printer is receiving data from the host computer.
- Make sure that the correct protocol is enabled. (Refer to Appendix A.2 Configuring the Printer and Appendix B Interface Description)
- Make sure that you have selected the correct port (if the automatic feature has not been selected).
- Make sure that paper is loaded.
- Make sure that the ribbon is installed.
- Examine the ribbon path. Does the ribbon pass in front of the whole printhead? Adjust the ribbon if necessary.
- Fanfold paper in lower or upper tractor does not advance
- Make sure that the right tractor is selected.

5.2.2 Operation related problems

Paper is not positioned at perforation for tear-off

- Select the correct form length using the Set-up feature.
- Set top of form by performing a Parking function.
- Refer to Appendix **A.4 Vertical Positioning Adjustment**.

Paper tears or jams

- Examine the paper path; remove any obstructions
- Is the paper too loose or too taut between the tractors?
- If the holes in the paper are deformed at their outer edges, the paper is too taut.
- If the paper rises between the tractors, it is too loose.
- Readjust the tractor spacing so that the paper lies smoothly but without any tension.
- Ensure that the paper is horizontally aligned on the pins.
- Open the printer's top cover. If necessary, loosen the two green screws and remove the paper guide plate to gain access to the paper

Parking paper and resetting top of form

Tear off paper on perforation (fold)

Press 

Press  until the paper is in the park position.

Press  Printing will resume at the top of the next form.

Print head carriage does not move smoothly/does not move at all

- Examine the paper path. Remove any obstructions.
- Examine the carriage area for obstructions. Remove, where necessary.
- Press  until the paper is in the park position.
- Make sure that the transport lock has been removed
-

5.2.3 Print related problems

Expression weak or of poor quality.

- Was the right paper used? Chapter 7 Technical Data contains a detailed specification of usable paper types. Replace the paper if it does not conform to specification.
- Check that the ribbon is properly tensioned.
- Does the ribbon have to be replaced? If necessary, replace with a new ribbon.
- Is the ribbon cassette used correctly? Adjust if necessary.

Characters do not print evenly or are not uniform in pitch

- Examine the paper path for dirt or other obstruction that may cause the gap between print head and platen to vary. Remove the obstruction.

Printed lines overlap.

- Examine the paper path for dirt or other obstructions that may prevent the platen from rotating freely. Remove the obstruction.

Part of printed text is missing (loss of data)

- If you are using Serial communications check the buffer control setting in Set-up.
- Check the data flow control setting on the host computer.

On Pre-Printed forms, the printing on the copies is not aligned with the Pre-Printed matter

- Adjustment via tractor vertical positioning
- Part of printed text is missing (loss of data)
- If you are using Serial-Communications check the buffer control setting in Set-up.
- Check the data flow control setting on the host computer.

If the printout or the character set is not ok, the following procedure can help to clear the situation.

SELECTION	RESULT	CHECK
Select and start PRINT TEST 1	Print not OK or partly missing?	<ul style="list-style-type: none"> • PAPER SOURCE • selection incorrect Ribbon worn or not installed • Print head worn
Stop SELF TEST and start regular printing	No printing starts	<ul style="list-style-type: none"> • Printer READY 1 ELQ ? • Interface cable not connected properly • Interface selection incorrectg
	Some characters are not correct	<ul style="list-style-type: none"> • Emulation • Character set • National version • Word length • Baud rate • Parity bit • Protocol
	Font (FONT) nd / or Pitch quality false	<ul style="list-style-type: none"> • Font • Pitch • Line
	Problem still there?	Call servive

5.2.4 Problems with ribbon

If you have problems with the ribbon, make sure that the ribbon is:

- is properly tensioned (2)
- not worn or dried out (3)
- not torn or otherwise damaged (1)
- not out of clip (4)

Carriage does not move smoothly:

- Check the paper path.
- Remove any obstacles.
- Check if all packaging material has been removed.
- Check the carriage area for foreign objects.
- Remove any foreign objects.

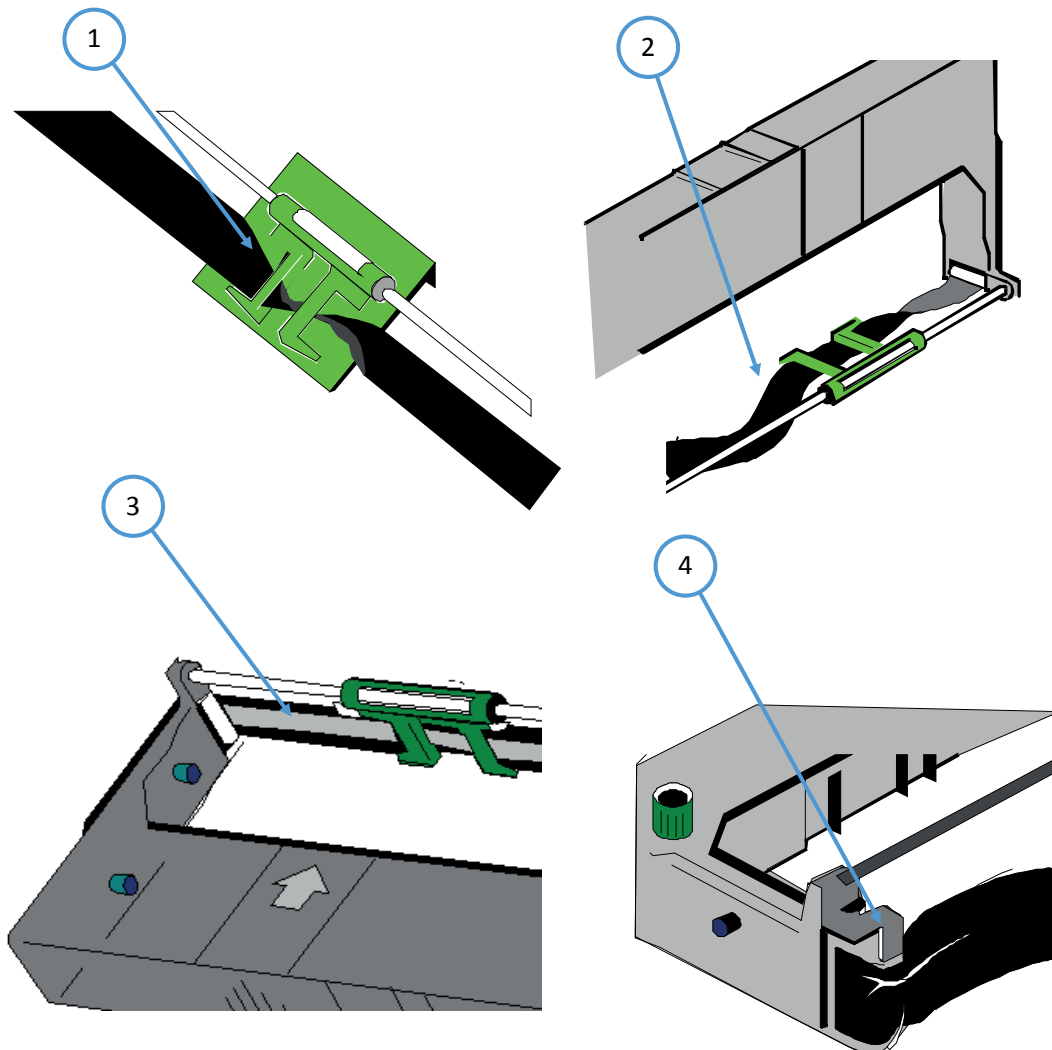

6. Procedures for Removal and Reassembly

This chapter describes the removal procedures which are necessary for proper handling of the spare parts and subunits of the printer.

For detailed order information and description of the spare parts see list

Note: All removal procedures consists of several steps.

- to show preparation
- to indicate the main removal steps.

Part: Housing 404/5 (3)

Part No.: 5112 292 3840x

Part: Top Cover 404 (1)

Order No.: 5322 447 80485

Part No.: 5112 292 7443x

Part: Front Cover 404 (2)

Order No.: 5322 442 01204

Part No.: 5112 212 6898x

Order No.: 5322 442 01203

FSI 5112 991 16641

Steps: Remove Part

- Disconnect mains cable
- Remove the front cover (2)
- Swing top cover (1) to its nearly upright position and remove it
- Remove the housing (3) by releasing the cover snap locks with a flat bladed screwdriver (4)
- To remove the housing (1) grasp it by the sides, raise the front slightly, push the housing back until the metal snaps are out of the slots at the rear of the printer and then lift up the housing.

REASSEMBLING

- Execute the REMOVAL procedure in reverse sequence

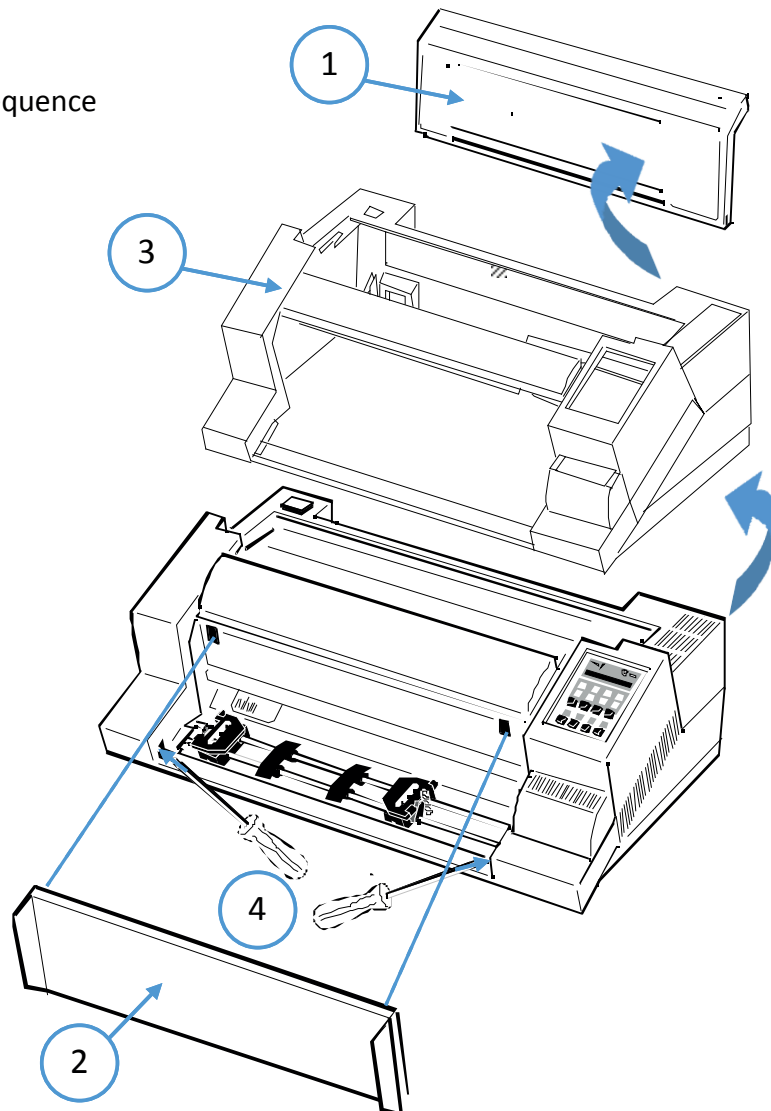

Part: Housing 404/5 (5)

Part: Top Cover 405 (2)

Part: Front Cover 405 (3)

Part: Front Insertion 405 (4)

Part: Stacker Support 405 (5)

Part No.: 5112 292 3840x

Order No.: 5322 447 80485

Part No.: 5112 292 3841x

Order No.: 5322 447 80486

Part No.: 5112 212 5490x

Order No.: 5322 447 80637

Part No.: 5112 292 3842x

Order No.: 5322 44740487

Part No.: 5112 2125500x

Order No.: 5322 447 80638

FSI 5112 991 10786

Steps: Remove Part

- Disconnect mains cable
- Remove the front cover (2), Stacker support (1), Front insertion (4)
- Swing top cover (2) to its nearly upright position and remove it
- Remove the housing (5) by releasing the cover snap locks with a flat bladed screwdriver (6)
- To remove the housing (5) grasp it by the sides, raise the front slightly, push the housing back until the metal snaps are out of the slots at the rear of the printer and then lift up the housing.

REASSEMBLING

- Execute the REMOVAL procedure in reverse sequence

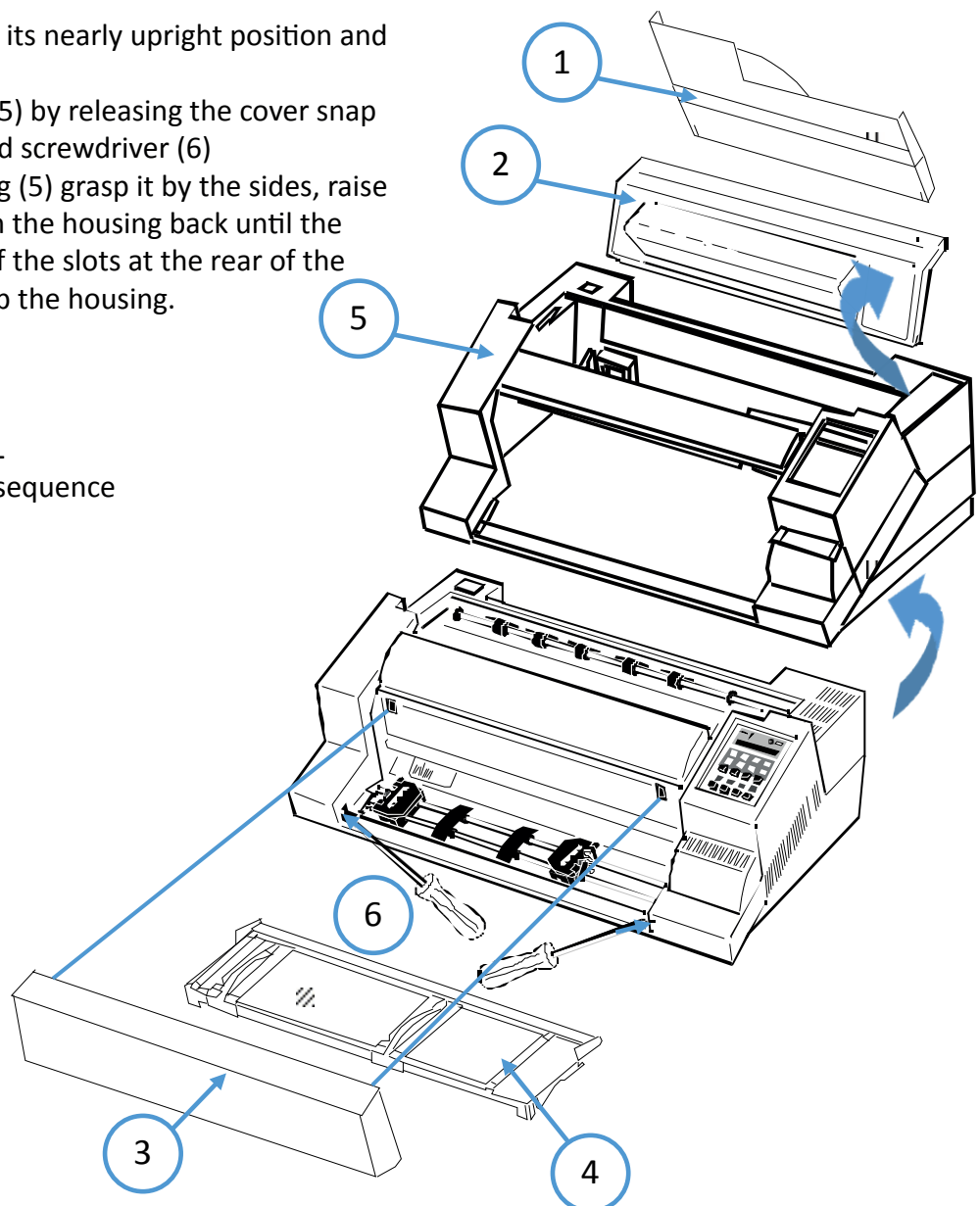

Part: PSU 405-2

Part No.: 5112 293 00021

Order No.: 8707 901 00028

FSI: 5112 991 21001

Steps: Remove Part

- Disconnect mains cable
- Remove all encasing parts (see Part: Housing)
- Loosen the two screws (11) and remove the power switch (5), Remove all cables (8) to DEV
- Remove the metal grounding plate (1) by loosen 3 screws (2) and put the power switch cable out of the holder (3) lift the plate out
- Loosen the two screws (5) and remove the power switch
- Loosen the two screws (4) securing the mechanical assembly Hang out the mechanical assembly (6) with the electronic boards DEV2 and PSU2 Hang out the complete electronic board
- Disconnect the cable from the DEV2
- Loosen the two screws (7) and lift the complete Power Supply Unit
- Remove the clamp and disconnect plug (9)

Attention: Do not touch the PSU2 board within 2 minutes after power OFF before exchanging the PSU, please check the fuse (8)

REASSEMBLING

- Execute the REMOVAL procedure in reverse sequence

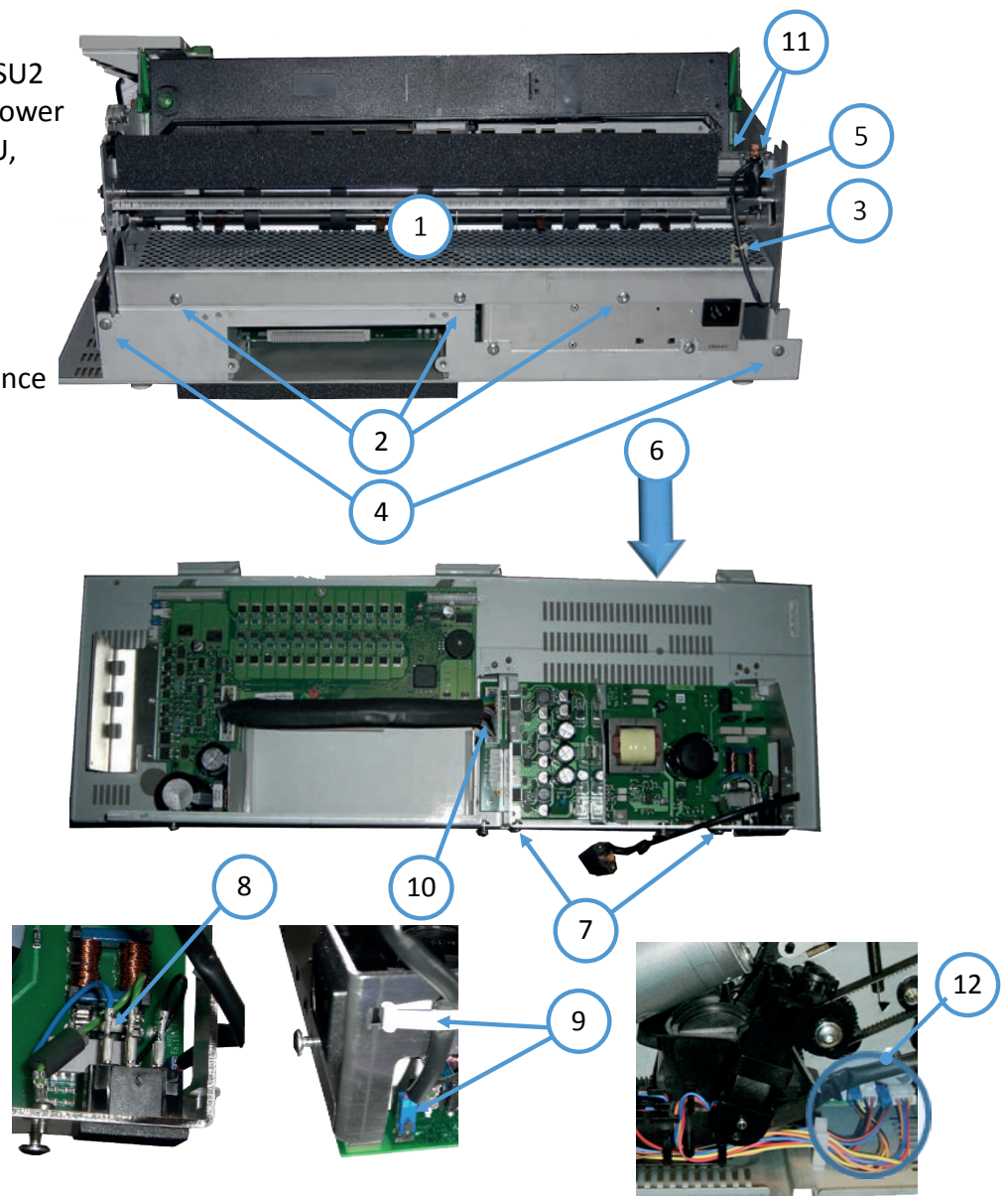

Part: DEV 404/5-2

Part No.: 5112 293 00022
 Order No.: 8707 901 00029
 FSI: 5112 991 21011

Steps: Remove Part

- Disconnect mains cable
- Remove all encasing parts (see Part: Housing)
- Loosen the two screws (11) and remove the power switch (5)
- Remove all cables (8) to DEV
- Remove the metal grounding plate (1) by loosen 3 screws (2) and put the power switch cable out of the holder (3) lift the plate out
- Loosen the two screws (4) securing the mechanical assembly Hang out the mechanical assembly (6) whit the electronic boards DEV2 and PSU2 Hang out the complete electronic board
- Disconnect the cable (9) from the PSU
- Loosen the four screws (7) and lift the complete DEV Unit

Attention: Do not touch the PSU2 board within 2 minutes after power OFF before exchanging the PSU, please check the fuse (8)

REASSEMBLING

- Execute the REMOVAL procedure in reverse sequence

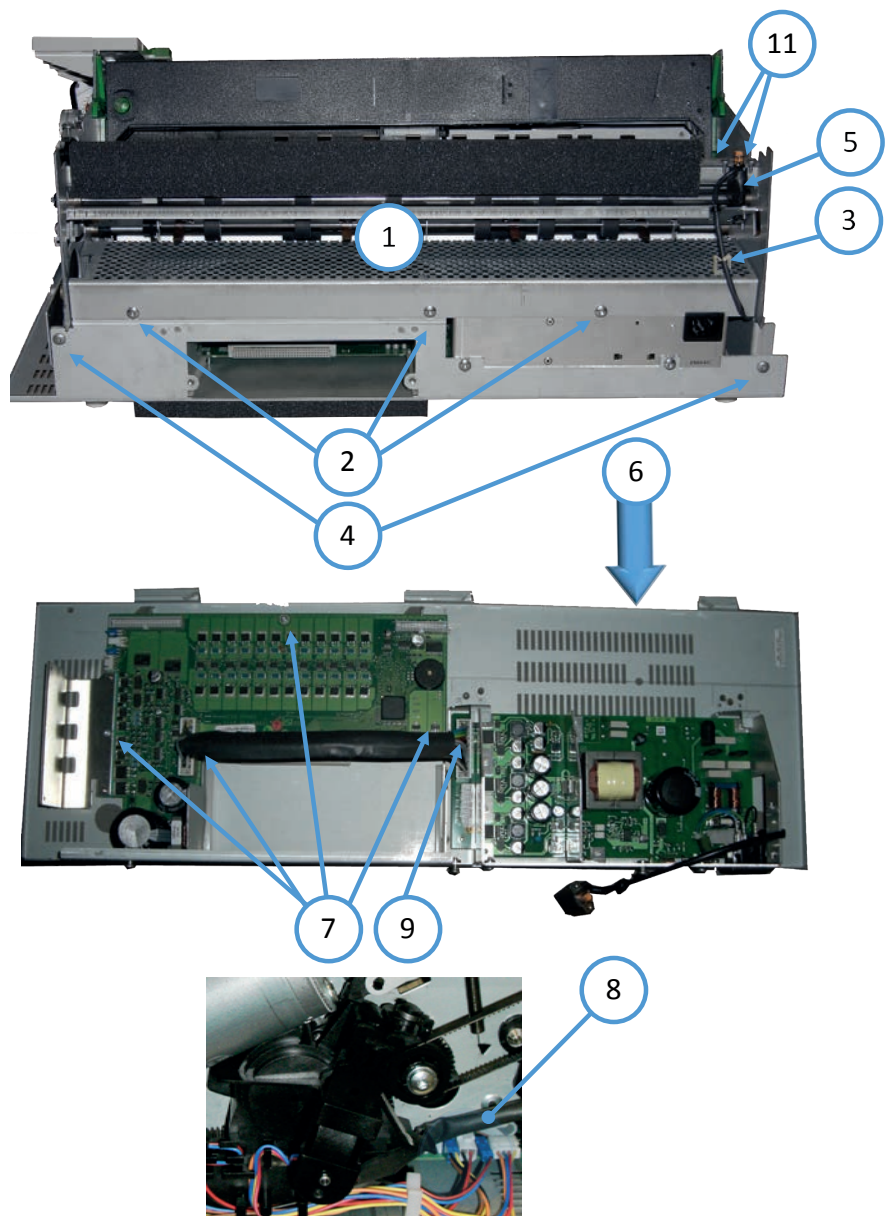

Part: Power Switch 40A

Part No.: 5112 292 3882x
Order No.: 5322 276 12685
FSI: 5112 991 10713

Steps: Remove Part

- Disconnect mains cable
- Remove all encasing parts (see Part: Housing)
- Loosen the two screws (1)
- Remove PSU2 (see Part: PSU 2 PP405)
- Remove the clamp and disconnect plug (2)
- Remove the power switch

REASSEMBLING

- Execute the REMOVAL procedure in reverse sequence

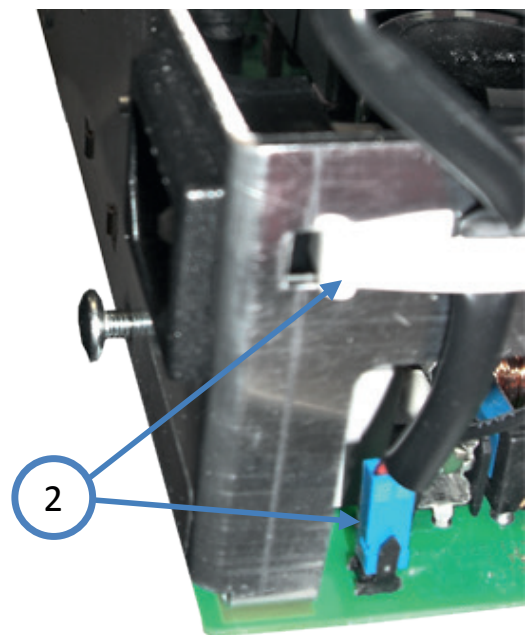
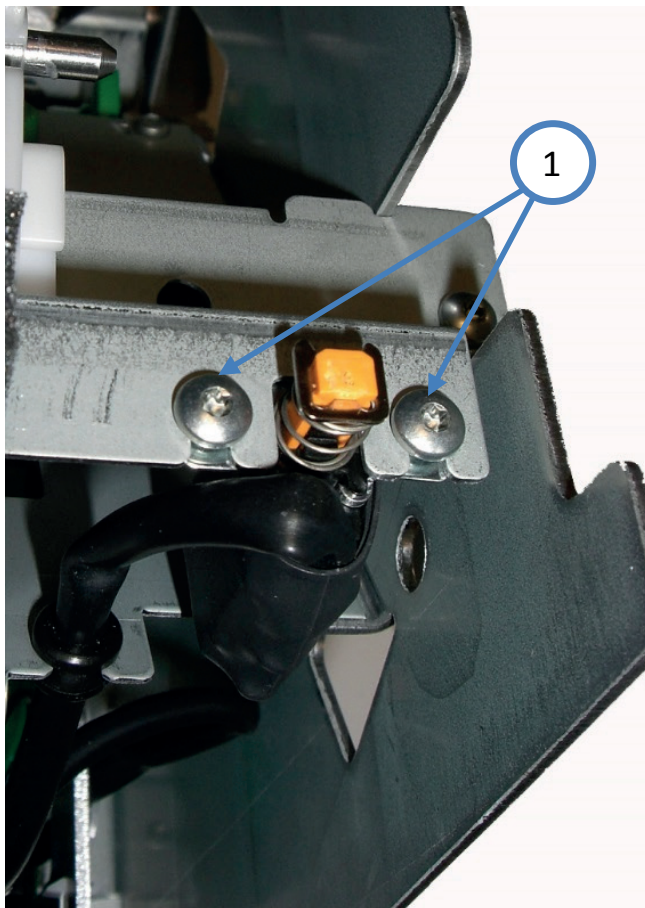

Part: Lubrication Felt

Part No.: 5112 212 5589x

Order No.: 5322 310 32108

FSI: 5112 991 12393

Steps: Remove Part

- Disconnect mains cable
- Remove all encasing parts (see Part: Housing)
- Remove Encoder Strip 2 (1) (see Part: Encoder Strip 2)
- Remove operator panel, but leave the interface cable connected (see Part: Operator Panel 40B - R)
- Remove screw (2) on both sides of the upper guide rail (3)
- Remove the upper guide rail (3)
- Exchange the lubrication felt (4). Insert the new felt with flatten ear (5) towards the operator panel

REASSEMBLING

- Execute the REMOVAL procedure in reverse sequence

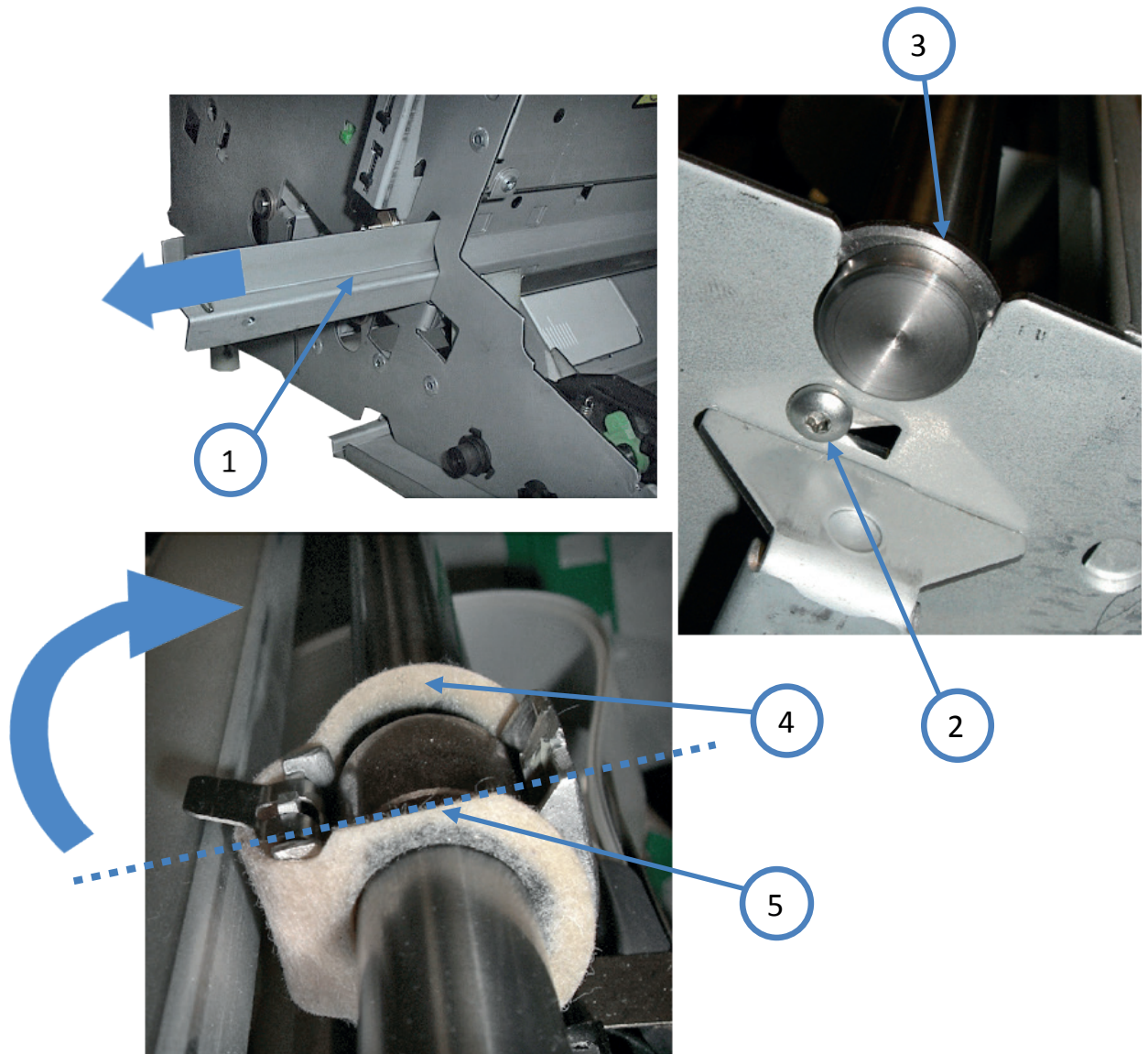

Part: Print H-Encoder

Part No.: 5112 293 0360x
Order No.: 8707 901 00031
FSI: 5112 991 21031

Steps: Remove Part

- Disconnect mains cable
- Remove all encasing parts (see Part: Housing)
- Remove encoder strip (3) by loosen screw (5) (see Part: Encoder Strip 2)
- Remove the noise reduction foam (1)
- Loosen at the left and right side the screws (6) and Remove the mounting plate (4)
- Move the carriage to the cutout (8)
- Remove the two screws (7) from the carriage
- Remove the screw (9) and the cable clamp from the carriage
- Disconnect the print head cable from the head
- Clip the plastic support (11) by open clips (10) from the carriage and disconnect the wire-to-wire connector (2) H-Encoder/print head cable
- Remove the print head H-encoder

see picture next page.

REASSEMBLING

- Execute the REMOVAL procedure in reverse sequence

Note: Pay attention that the logic cable is fixed correctly by clamp (10)

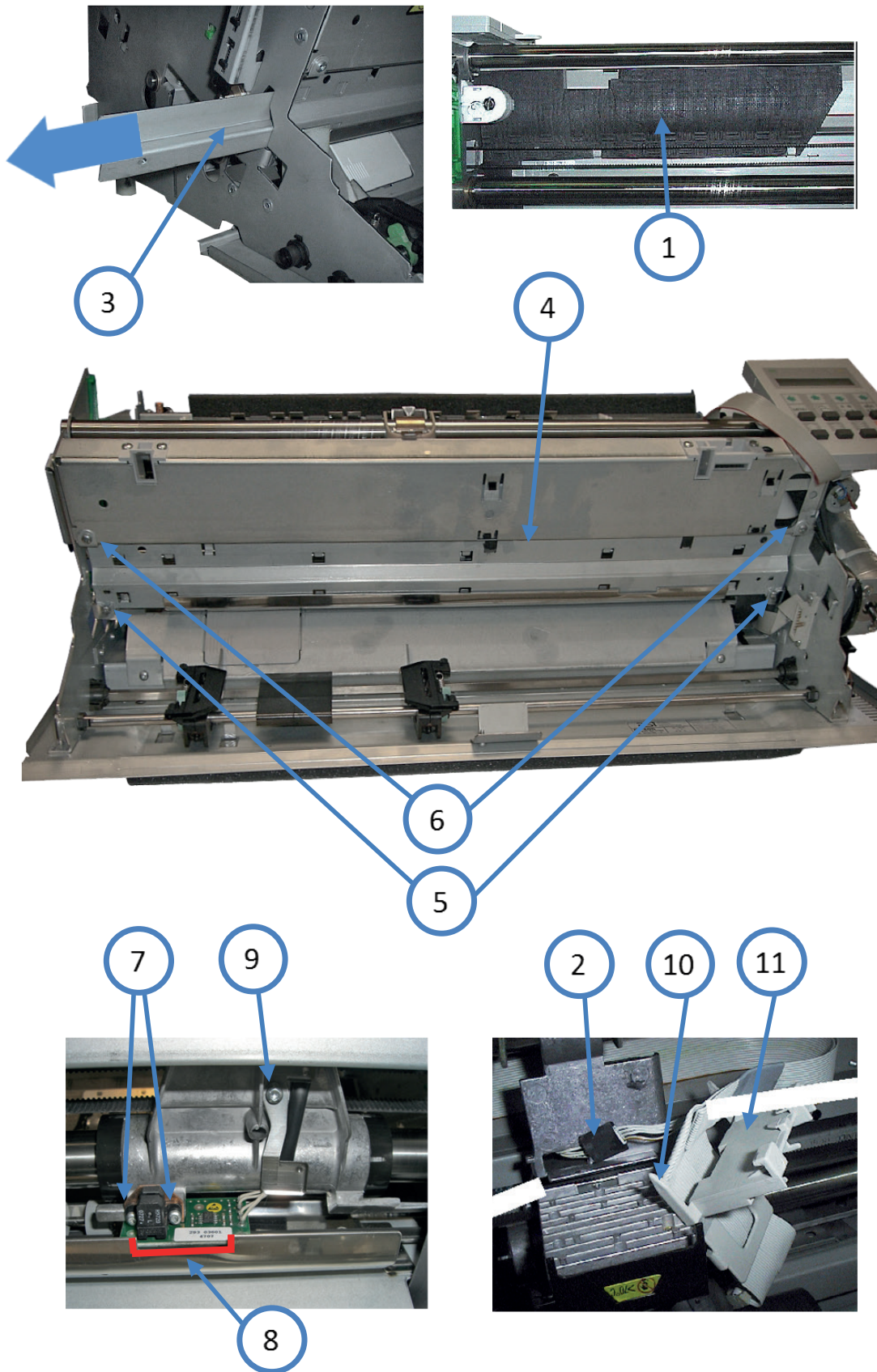

Part: Operator Panel 40B-R

Part No: 5112 292 6418X
Order No: 8707 901 00015
FSI: 5112 991 13284

Steps: Remove Part

- Disconnect mains cable
- Remove all encasing parts (see Part: Housing)
- Loosen the fixation screw (1) underneath of the operator panel
- Disconnect the connection cable from plug (2)
- Remove the Operator Panel Assy

REASSEMBLING

- Execute the REMOVAL procedure in reverse sequence

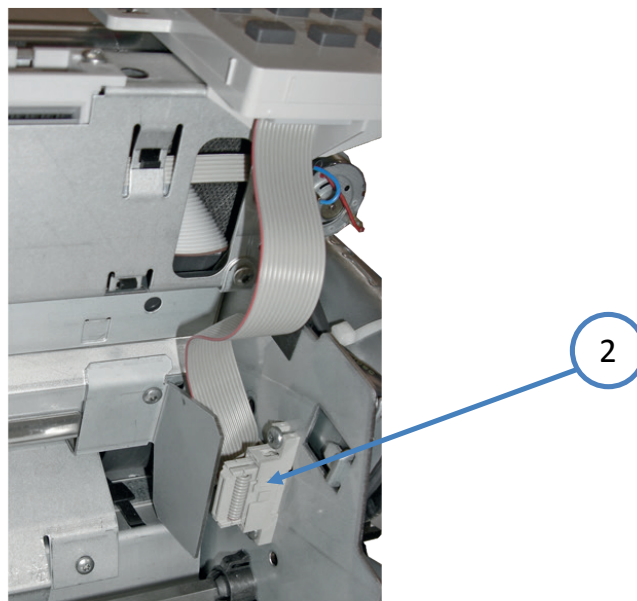
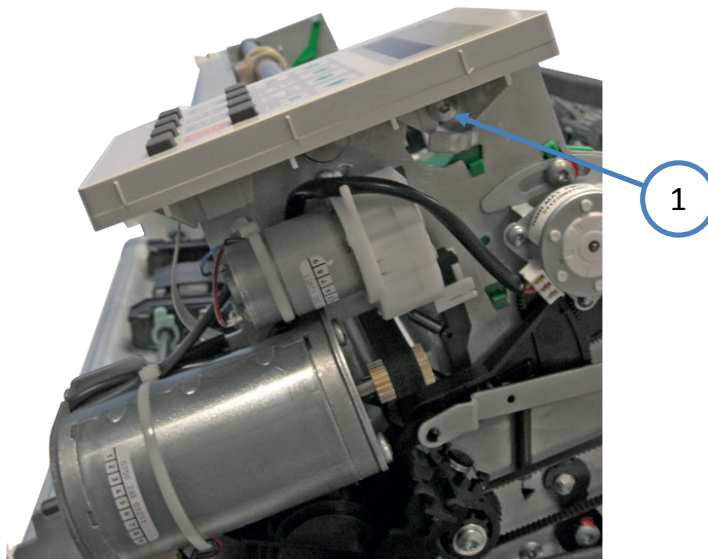

Part: Print Head Cable 407/8-2

Part No: 5112 280 1277x
 Order No: 8707 901 00030
 FSI: 5112 991 21021

Steps: Remove Part

- Disconnect mains cable, Remove Housing
- Remove encoder strip (1) (see Part: Encoder Strip 2)
- Remove the noise reduction foam (2) from the cable channel and remove the two plastic clips (7)
- Clip the plastic support (3) from the print head carriage, by first releasing clamps (4)
- Disconnect print head cable (6) from the print head and the wire-to-wire connection (5) of the H-Encoder
- Hang out the mechanical assembly with the electronic boards DEV2 and PSU2 (see Part: DEV 2 / PSU2) and disconnect the print head cables (8) from DEV2
- Remove the print head cable

REASSEMBLING

- Execute the REMOVAL procedure in reverse sequence

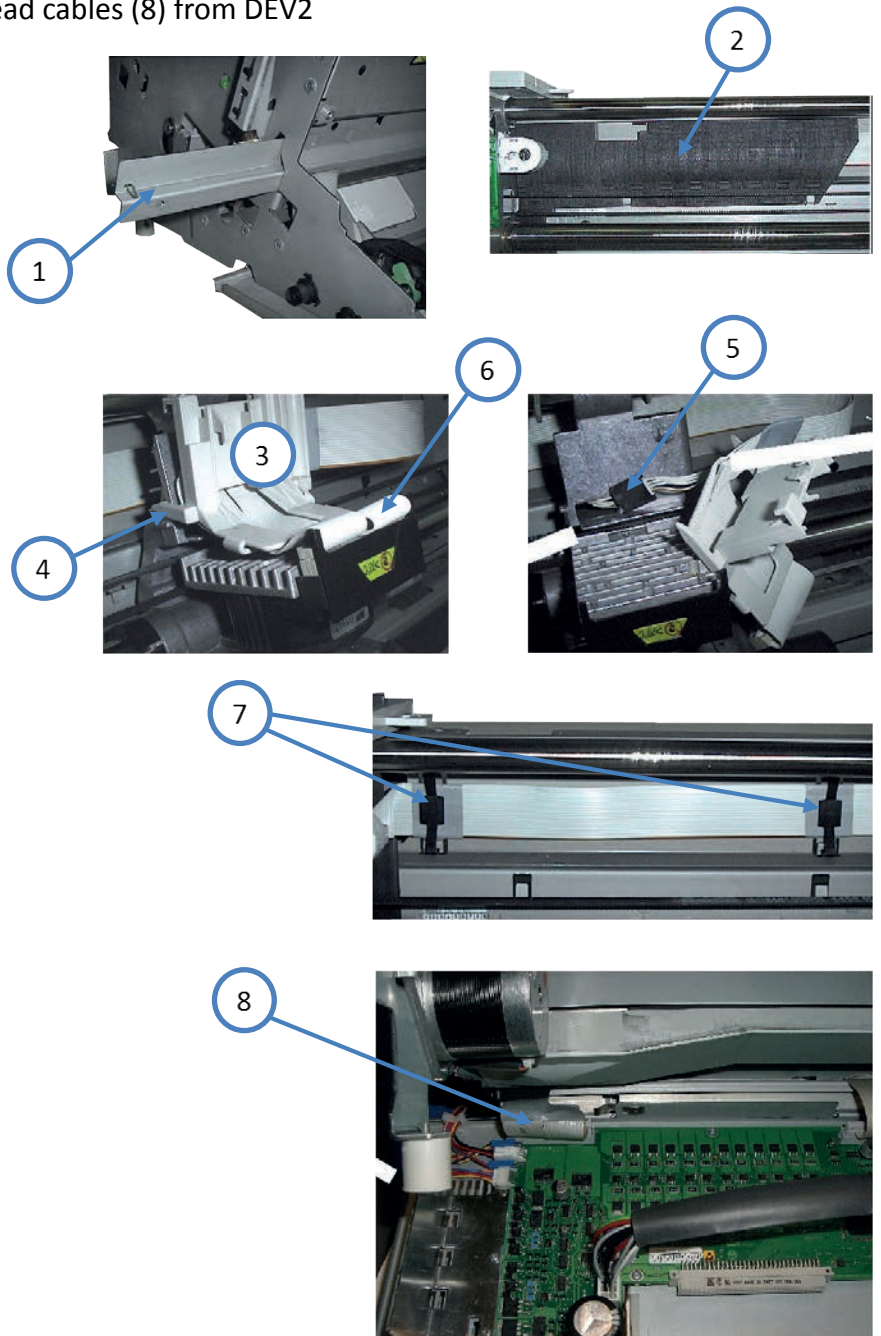

Part: Encoder Stripe 2

Part No: 5112 292 7454X
 Order No: 5322 466 11114
 FSI: 5112 991 21101

Steps: Remove Part

- Disconnect mains cable
- Remove all encasing parts (see Part: Housing)
- Remove the two screws on the left (1) and right (2) side and remove
- The two metal plates (4)
- Remove the encoder strip (3)

Caution: Please don't touch the lineal

REASSEMBLING

Move the carriage to the center position.

- Execute the REMOVAL procedure in reverse sequence

Caution: Please pay attention, that the encoder strip is mounted in the correct position and assure, that the strip is slipping underneath the first two steel noses (4), visible from the front side of the printer.

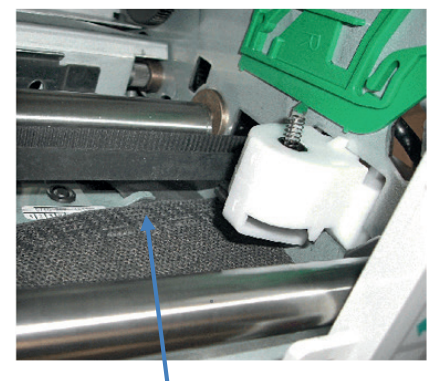
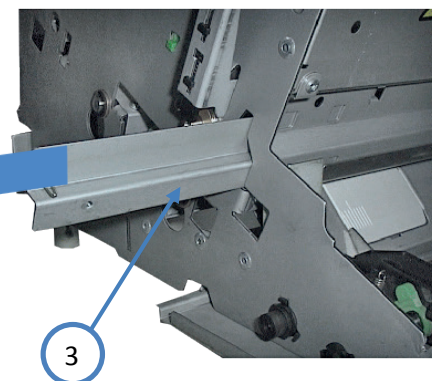
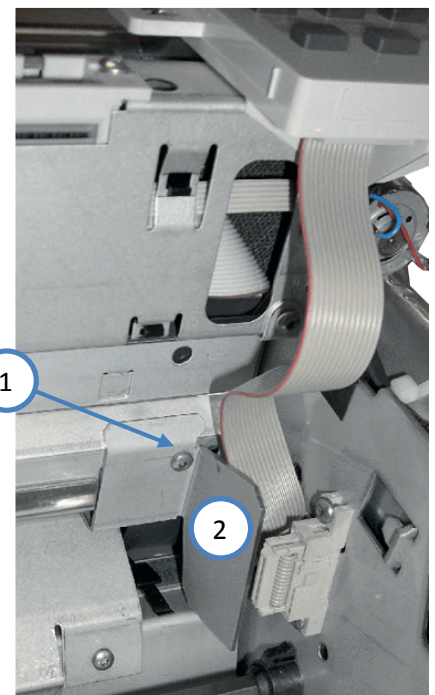
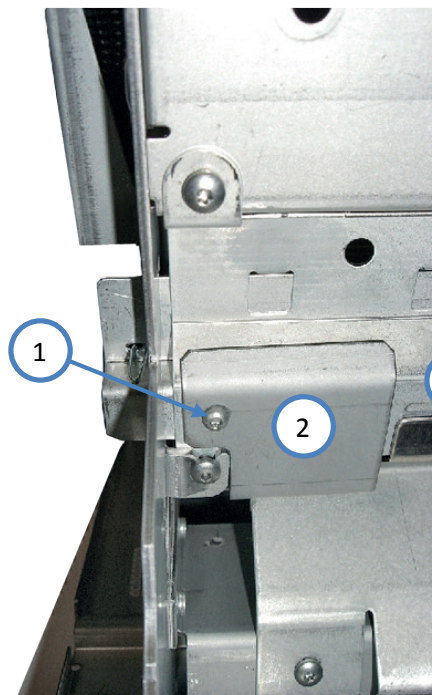

Part: Stepper Motor 1.8 DEG-2

Part No: 5112 280 1286X

Order No: 8707 901 00035

FSI: 5112 991 21081

Steps: Remove Part

- Disconnect mains cable
- Remove all encasing parts (see Part: Housing)
- Remove the motor cable (1) guide from the DEV2
- Hang out the mechanical assembly whit the electronic boards DEV2 and PSU2(see Part: DEV 2 404/5)
- Remove the two screws (1), of the vertical drive motor
- Turn the motor anti-clockwise and Remove it from the mounting lam p (2)
- Disconnect cable (5) and pull it out of the tractor gear (4)
- Disengage the drive belt (3) from the drive pinion and remove the motor (6)

REASSEMBLING

- Execute the REMOVAL procedure in reverse sequence

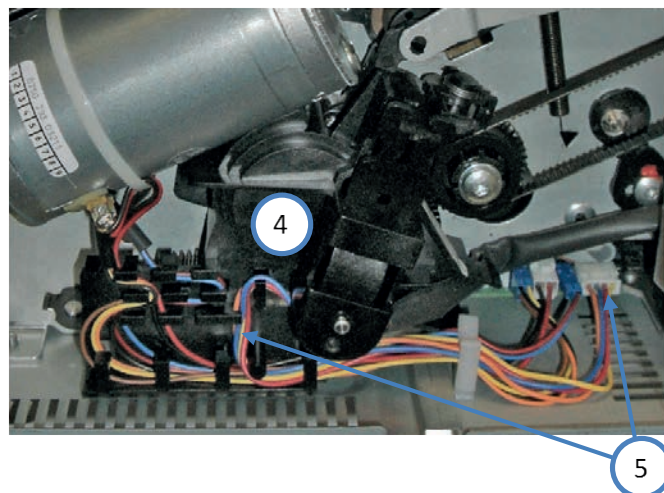
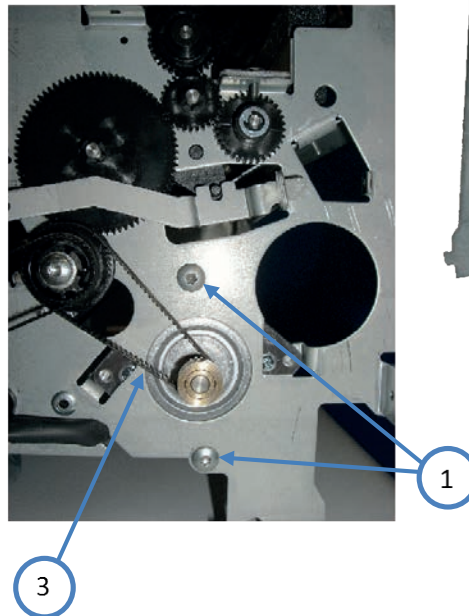

Part: Stepper Motor 7.5 DEG

Part No: 5112 209 2759X
Order No: 8707 901 00034
FSI: 5112 991 21071

Steps: Remove Part

- Disconnect mains cable
- Remove all encasing parts (see Part: Housing)
- Remove metal sheet
- Remove crews (1) of the AGC - Motor
- Remove the connection cable (4) of the AGC motor from the DEV (2)
- Unthread the cable from the holder (5)

Warning: Do not loosen lock tied screws (3). This is a factory adjustment; field adjustment is critical!

REASSEMBLING

- Execute the REMOVAL procedure in reverse sequence

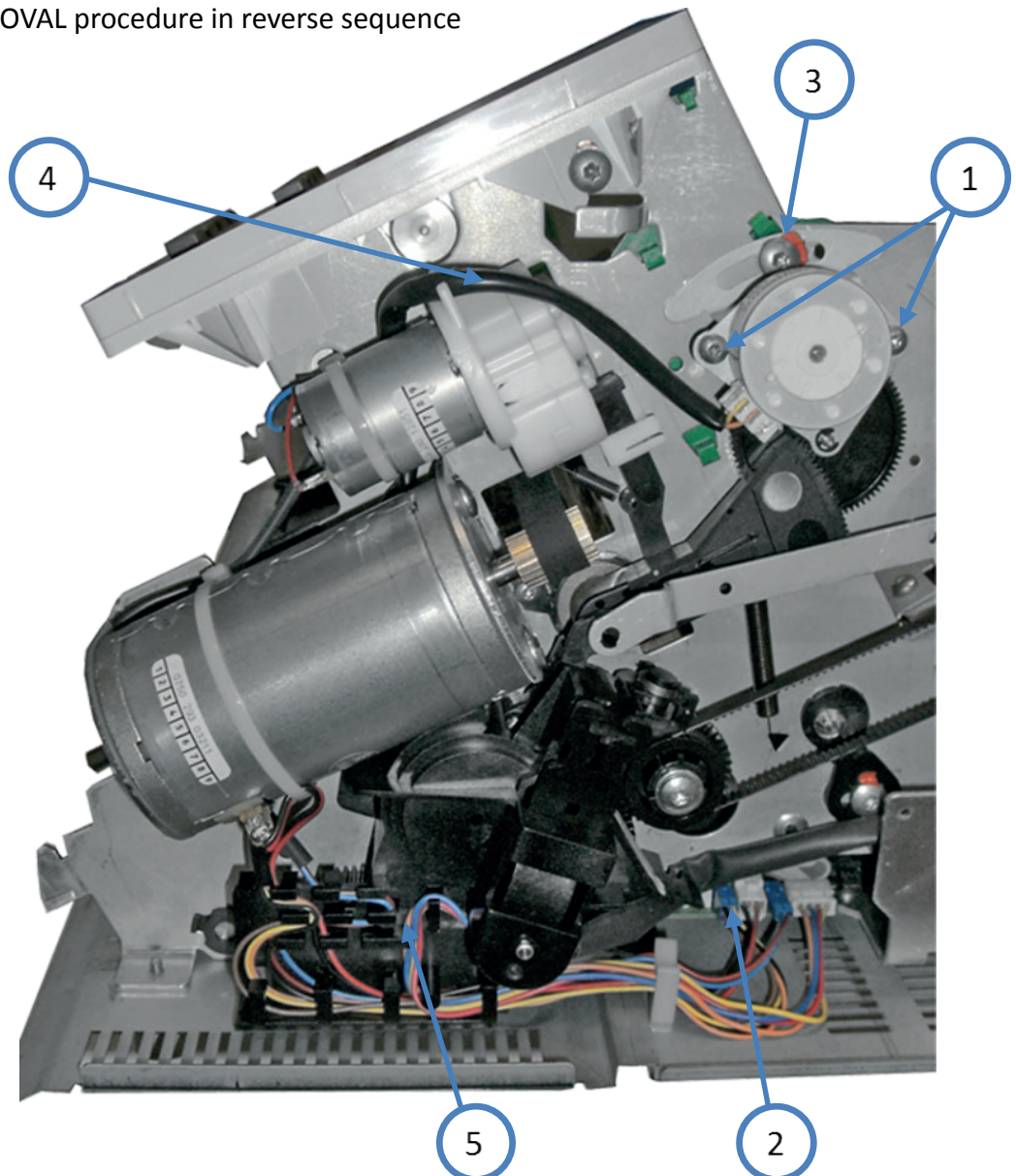

Part: Paper Sensor 407/8-R

Part No: 5112 293 6243X

Order No: 8707 901 00027

FSI: 5112 991 13383

Steps: Remove Part

- Disconnect mains cable
- Remove all encasing parts (see Part: Housing)
- Remove circlip (1) and bearing (2). let the axle (3) fall down
- Remove the Paper Sensor (4) by uplift (6) with a small screw Driver and pull out backwards.
- Disconnect the cable (5)

REASSEMBLING

- Execute the REMOVE procedure in reverse sequence

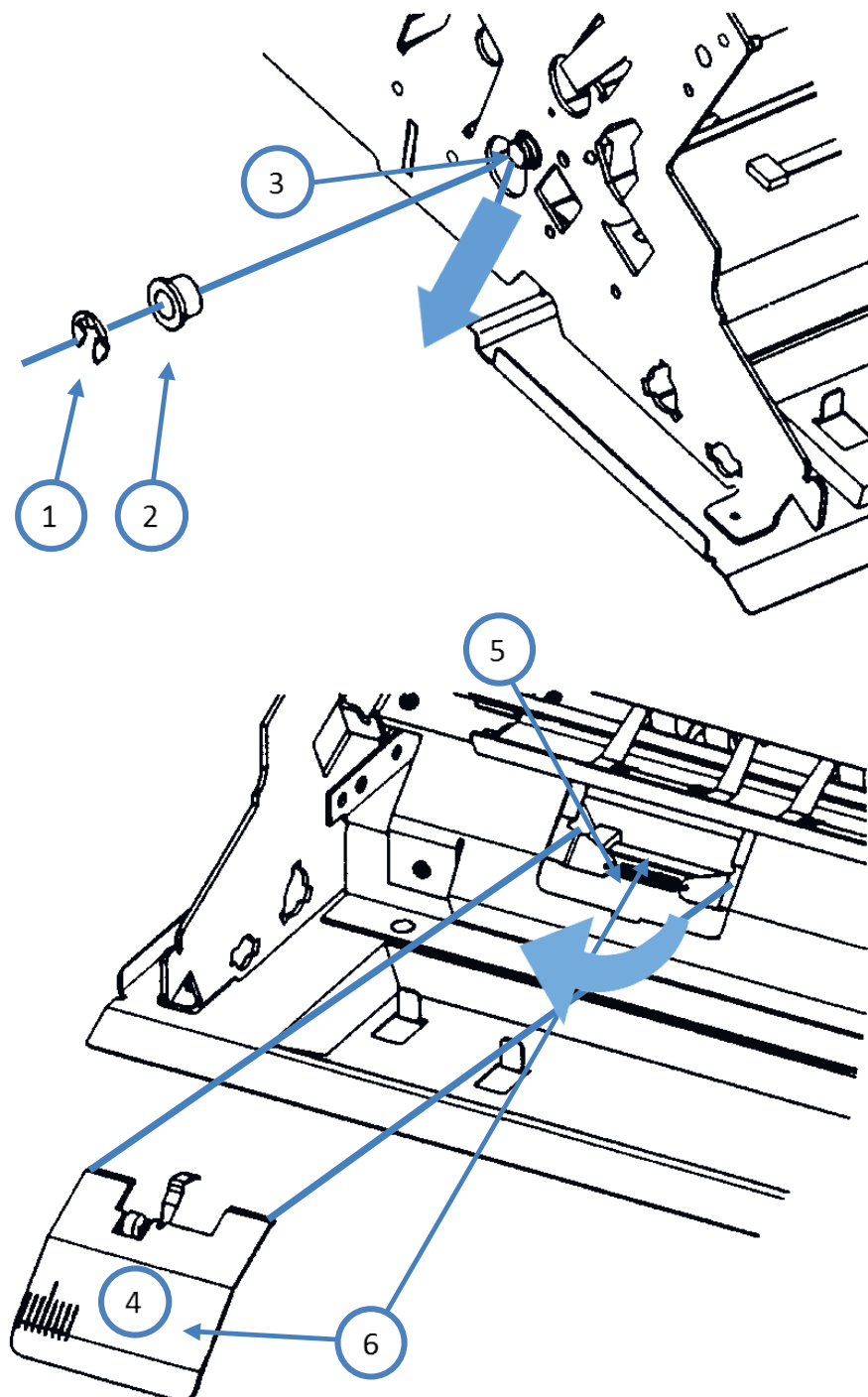

Part: H-Motor 404/5

Part No: 5112 293 0321x

Order No: 8707 901 00032

FSI: 5112 991 21041

Steps: Remove Part

- Disconnect mains cable
- Remove all encasing parts (see Part: Housing)
- Disengage the drive belt (1) from the drive wheel of the horizontal motor by pressing the belt tension element (2), which is located at the left side of the engine, upwards
- Pull off the belt from the wheel
- Disconnect the two pin motor cables (3) from the motors connector
- Remove the horizontal motor

REASSEMBLING

- Execute the REMOVAL procedure in reverse sequence

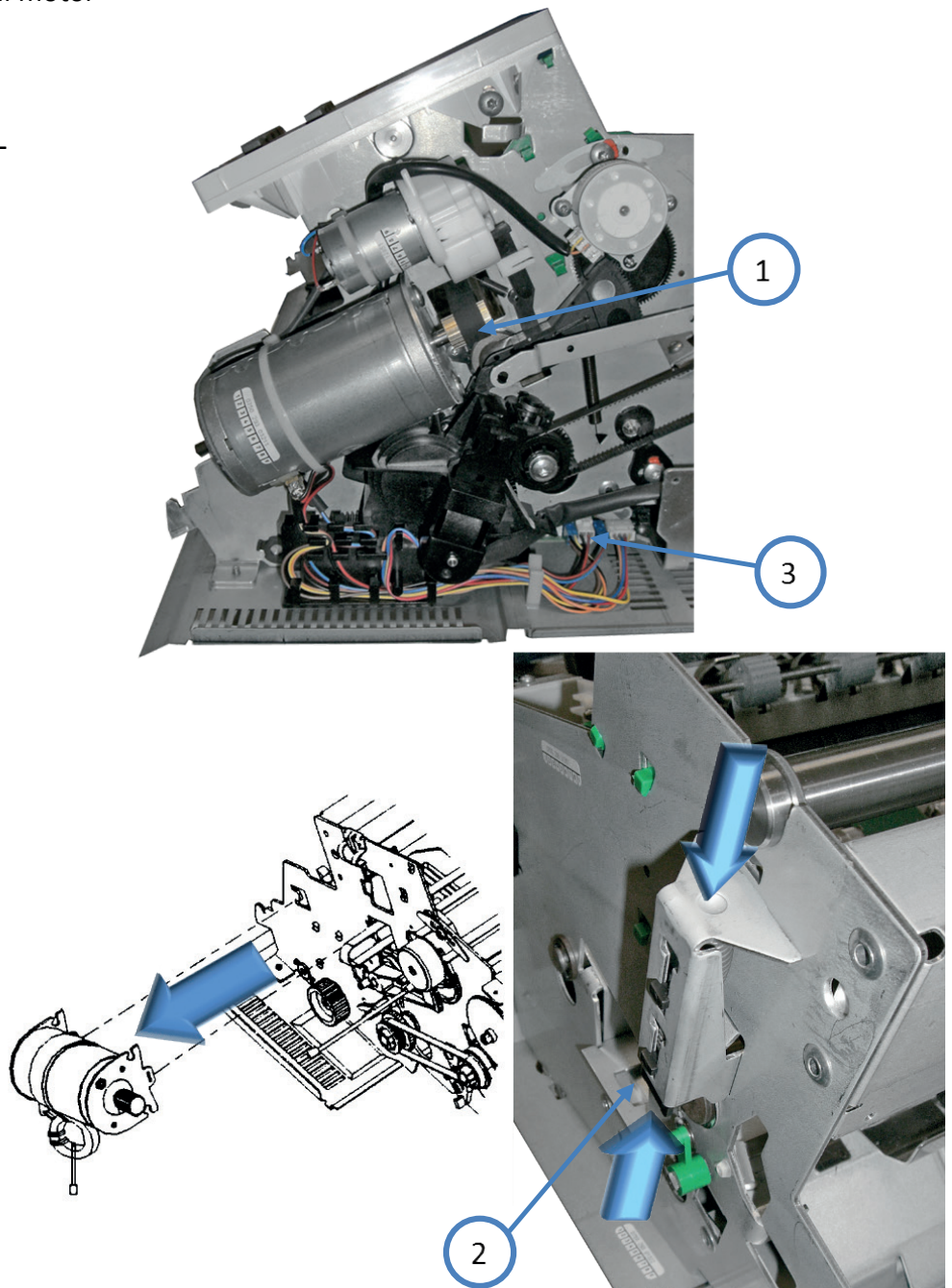

Part: Ribbon Gear-2

Part No: 5112 293 0327X
 Order No: 8707 901 00033
 FSI: 5112 991 21061

Steps: Remove Part

- Disconnect mains cable
- Remove all encasing parts (see Part: Housing)
- Locate the Ribbon Gear (1)
- Loosen the cable (2) from the cable guide (3)
- Loosen the spring (7) and Remove lever (6)
- Disconnect motor cable from the DEV (4)
- Push the lock tab (5) and Remove the Ribbon Gear

REASSEMBLING

- Execute the REMOVAL procedure in reverse sequence

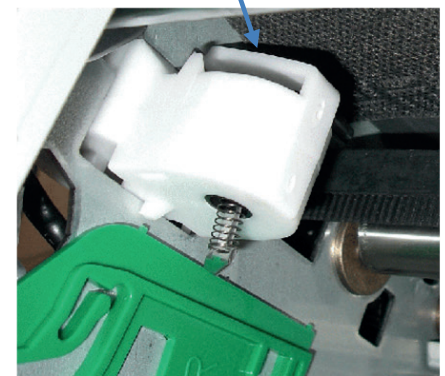
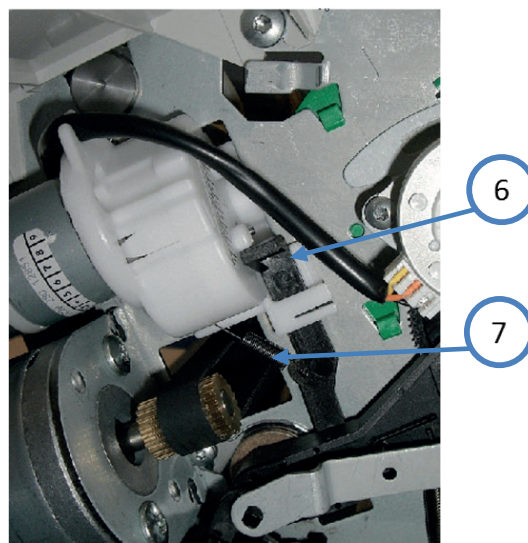
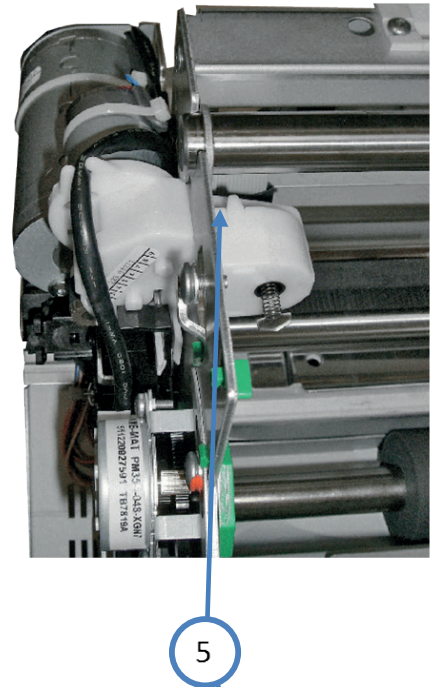
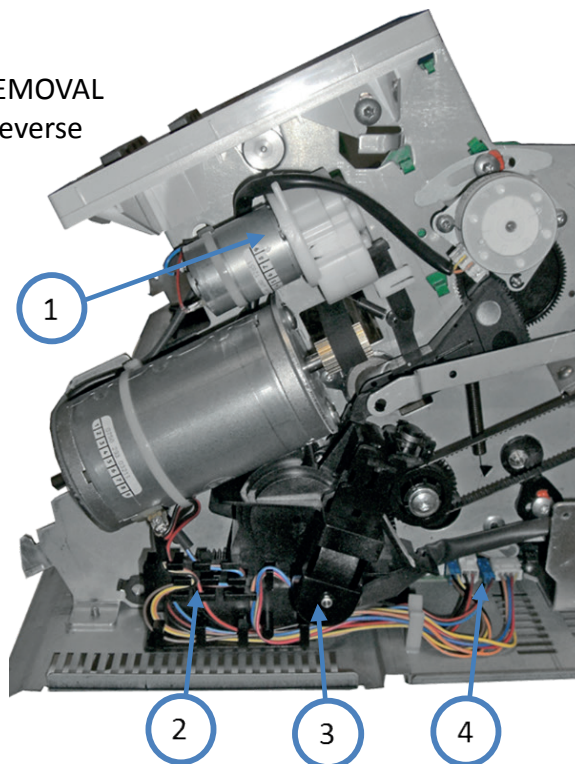

Part: Kit V-Transport 404**(Fanfold Printer)****Part: Kit V-Transport****(Multi-purpose Printer)****Part: Belt Stepper****Part: Belt Form Feed**

Part No.: 5112 292 7440x

Order No.: 5322 310 11123

Part No.: 5112 292 3845x

Order No.: 5322 310 31375

Part No.: 5112 200 0878x

Order No.: 5322 358 20369

Part No.: 5112 200 0879x

Order No.: 5322 358 20391

FSI 5112 991 10732

Steps: Remove Part

- Disconnect mains cable
- Remove all encasing parts (see Part: Housing)
- Locate the right side of the form feed shaft for exchanging
- Remove both mini pitch belts (1)
- Pull the belt pulley (2) from the wheel shaft for exchanging
- If the upper form feed shaft has to be exchanged Remove the bearing (3)
- Remove circlip (4) and bearing (5) on the left side from the wheel shaft for exchanging Removing the bearings causes the wheel shaft to fall down into the larger holes, for rem oval slide the wheel shaft to the left side

see picture next page.**REASSEMBLING**

- Execute the REMOVAL procedure in reverse sequence

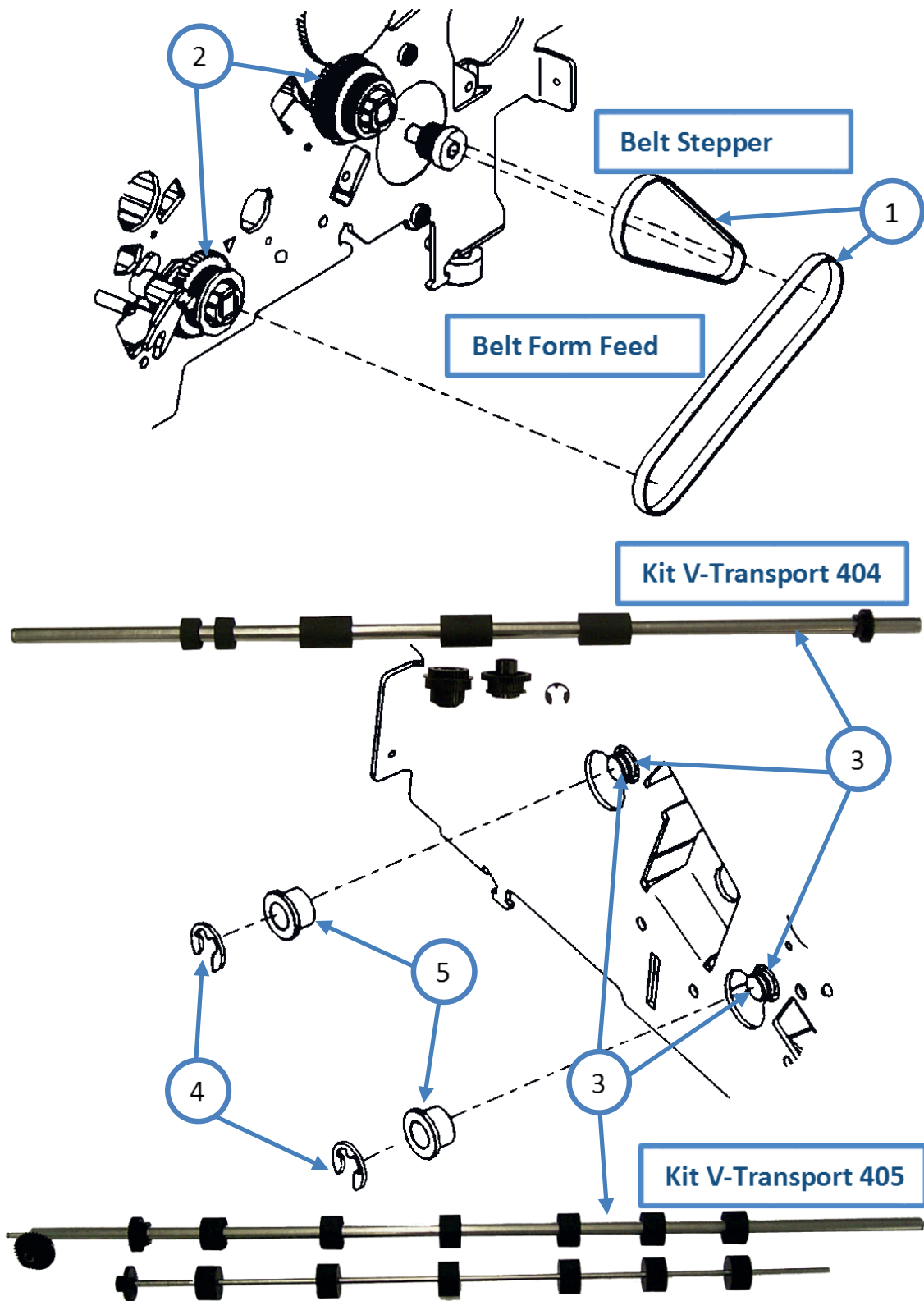

Part: Kit Pressure Rolls

Part No: 5112 292 6655x
 Order No.: 5322 310 32109
 FSI: 5112 991 12402

Steps: Remove Part

- Disconnect mains cable
- Remove all encasing parts (see Part: Housing)
- Remove the encoder strip (see Part: Encoder Strip 2)
- Remove the upper screws (1)
- Remove the foam underneath of print head cable
- Remove carriage (see Part: Carriage Assy)
- Snap out the springs (2) using a knife
- Remove the pressure roller (1)
- Grease the bearings of the pressure roller with Molykote DX or a similar type of grease
- Grease the arms of the new springs at the positions which are in contact with the FF1 with Molykote DX or a similar type of grease.
- Insert the new springs by snap in

REASSEMBLING

- Execute the REMOVAL procedure in reverse sequence

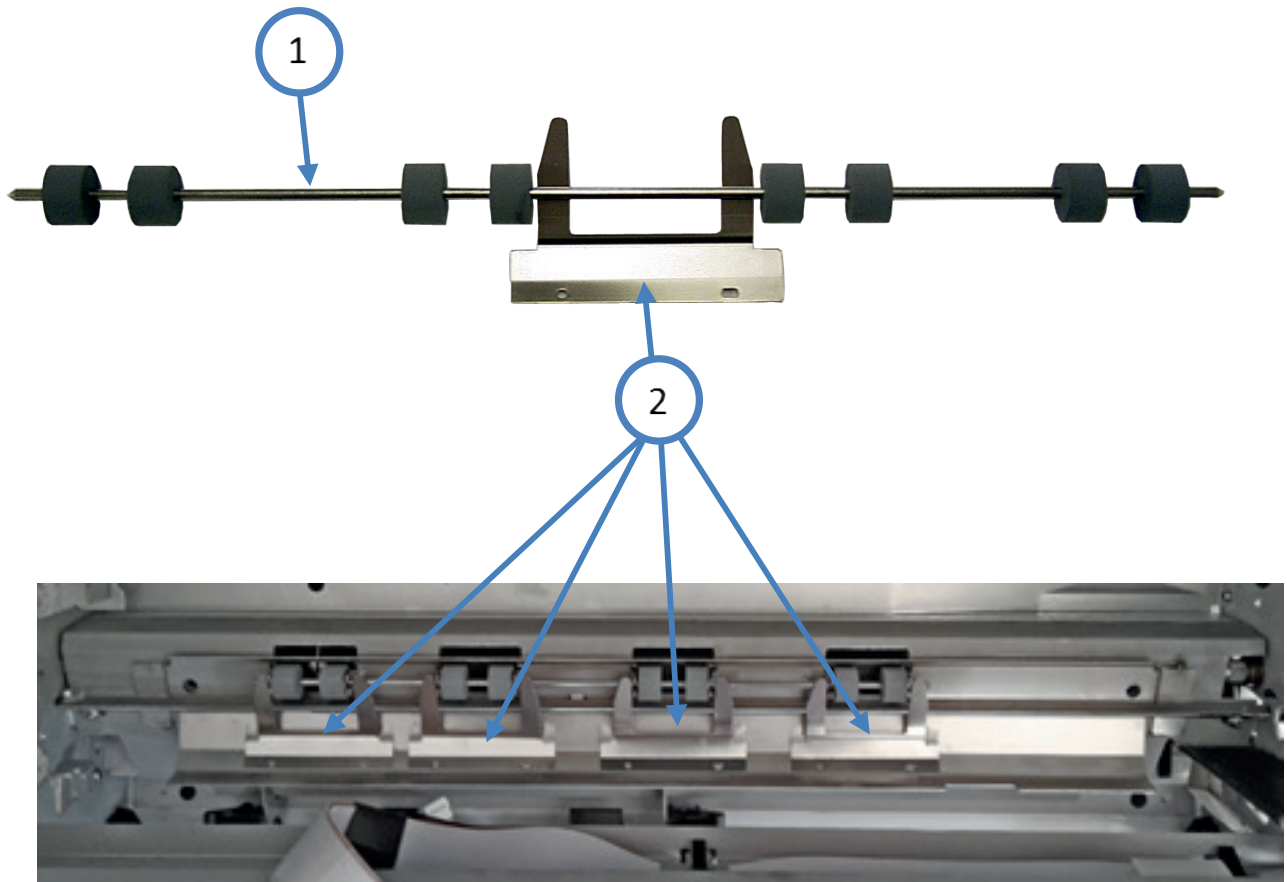

Part: Stacker Elements (Multi-purpose Printer)

Part No.: 5112 292 4099x
 Order No.: 5322 693 23073
 FSI: 5112 991 12402

Steps: Remove Part

- Disconnect mains cable
- Remove all encasing parts (see Part: Housing)
- Loosen the two screws (1) securing the Power ON/O FF switch
- Remove the two screws (2) which secure the stacker elements plate
- Remove the circlip (3) which secures the bearing (4)
- Slide the bearing (4) to the left and Remove the Stacker Elements

REASSEMBLING

- Execute the REMOVAL procedure in reverse sequence

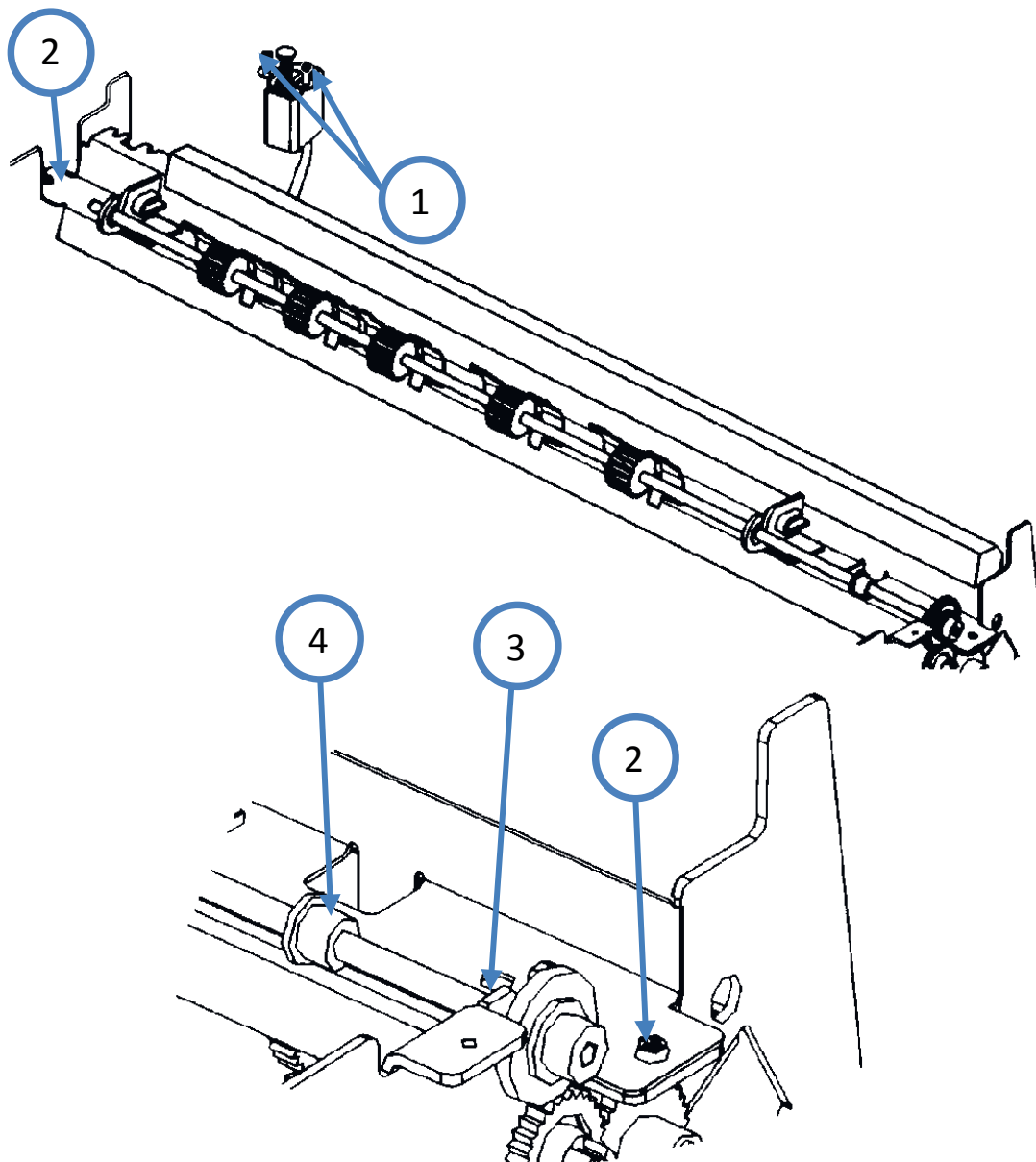

Part: Kit Cont. Forms Exit

Part No.: 5112 292 3846x

Order No.: 5322 310 31376

FSI: 5112 991 10742

Steps: Remove Part

- Disconnect mains cable
- Remove all encasing parts (see Part: Housing)
- Remove stacker elements (see Part: Stacker Elements)
- Locate the gearwheel (1), Remove the circlip (2) and the washer (3), Remove gearwheel (1) and bearing (4) from the wheel shaft
- Remove circlip (5) and bearing (4) from the wheel shaft and move It to the left. Remove the shaft
- Prepare the left hand side bearing of the pressure roll (6) such that it can be removed
- Remove the pressure roller continuous Exit (6)

REASSEMBLING

- Execute the REMOVAL procedure in reverse sequence

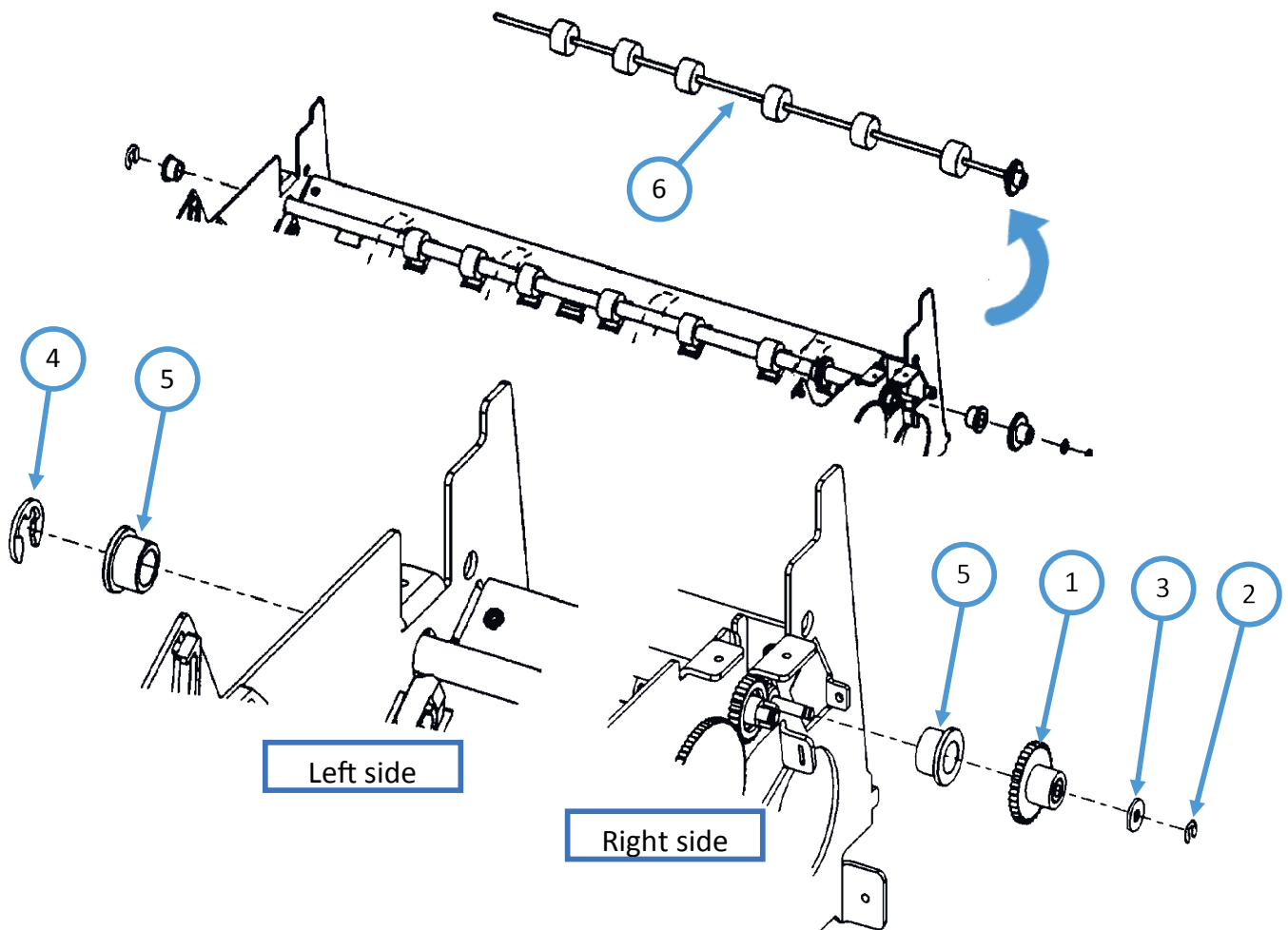

Part: Kit Belt Pulley 3 404/5

Part No.: 5112 292 7649x

Order No.: 5322 310 11313

FSI: 5112 991 12004

Steps: Remove Part

- Disconnect mains cable
- Remove all encasing parts (see Part: Housing)
- Locate the right side of the form feed shaft for exchanging
- Remove both mini pitch belts (1)
- Loosen Screw and washer (2) from FF1 axis
- Pull both belt pulley (2) from the wheel shaft to be exchanged

Note: please us by reassembly only new pulleys

REASSEMBLING

- Execute the REMOVAL procedure in reverse sequence

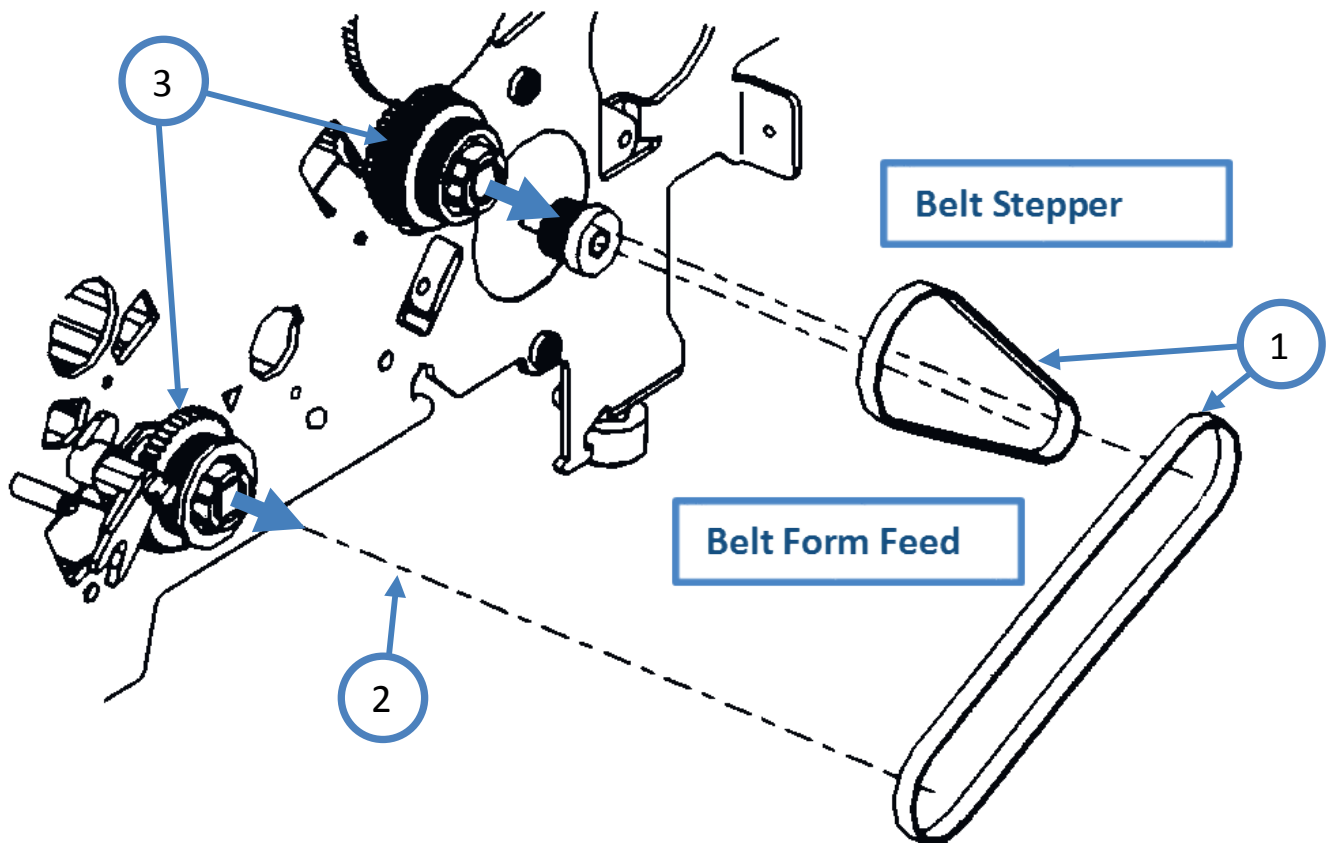

Part: Protection Shield

Part No.: 5112 292 3839x
 Order No.: 5322 446 92441
 FSI: 5112 991 10526

Steps: Remove Part

- Disconnect mains cable
- Open top cover
- Remove Ribbon Cassette
- Remove Platen (4) (see Platen)
- Remove protection shield (1) by loosening the two screws (2). This can easily be done by inserting of a torx screwdriver of at minimum 110 mm length through the holes (3) in the bottom plate and the platen channel

REASSEMBLING

- Execute the REMOVAL procedure in reverse sequence

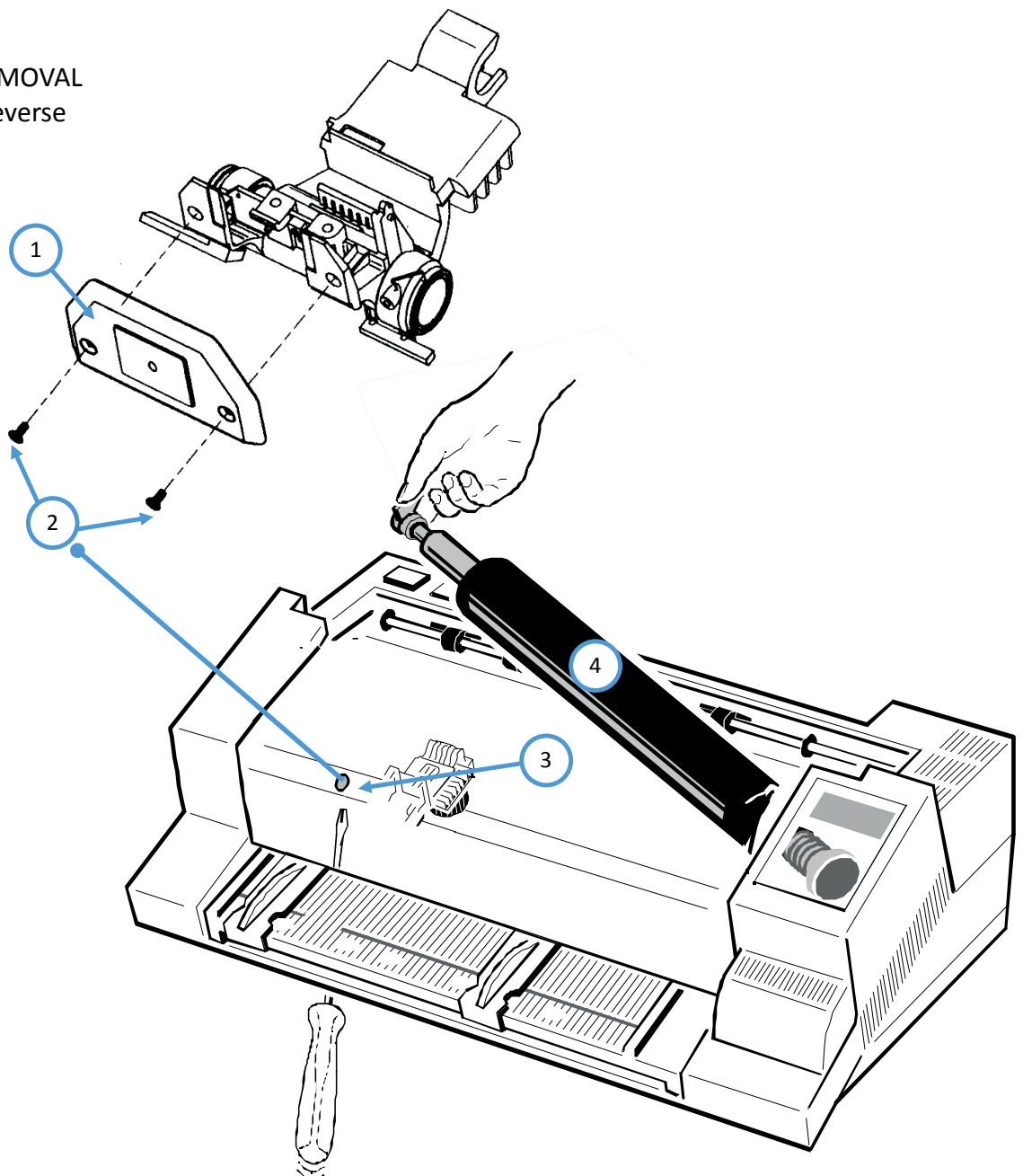

Part: H-Drive Belt

Part No.: 5112 292 3848x

Order No.: 5322 310 31374

FSI: 5112 991 10761

Steps: Remove Part

- Disconnect mains cable
- Remove all encasing parts (see Part: Housing)
- Remove the print head (see Print Head)
- Disengage the drive belt (1) from the drive wheel horizontal motor by pressing the belt tension elements on pos. (2) (see Part H-Motor)
- Slide the drive belt out of the drive wheel
- Remove the drive belt roller bearing (3) from its mounting bracket
- Remove the screw (4) and disengage the wedge (5) from the print head carriage

REASSEMBLING

- Execute the REMOVAL procedure in reverse sequence



1

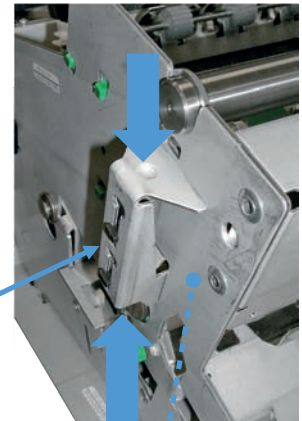

2

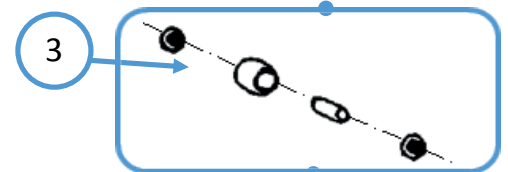

3

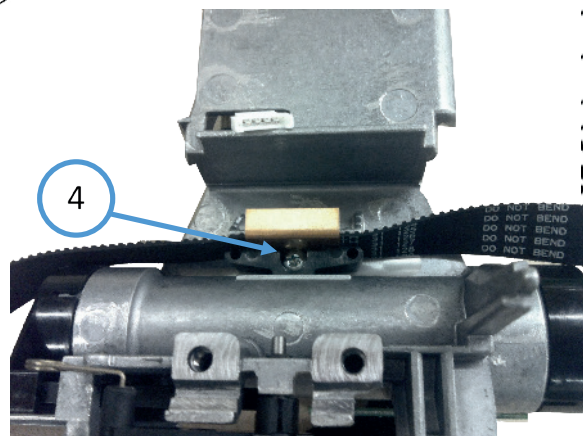
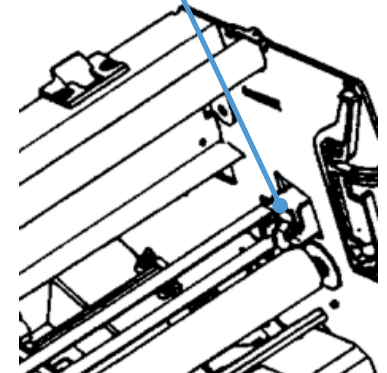
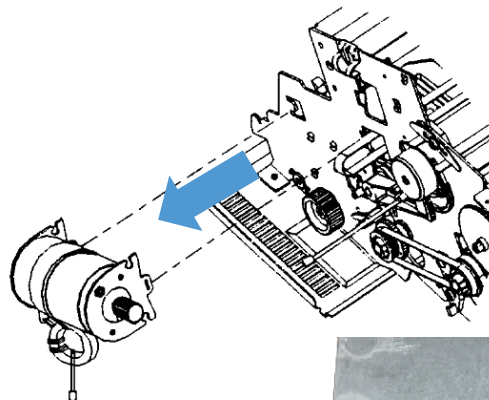

4

Part: Paper Guide 4 405

Part No: 5112-292-62861
Order No: 5322-466-11766

Part: Paper Guide 4 404

Part No: 5112-292-73351
Order No: 5322-466-11768

Steps: Remove Part

- Disconnect mains cable
- Remove top cover
- Remove Ribbon Cassette
- Remove Paper Guide 4 by screws (1)

REASSEMBLING

- Execute the REMOVAL procedure in reverse sequence

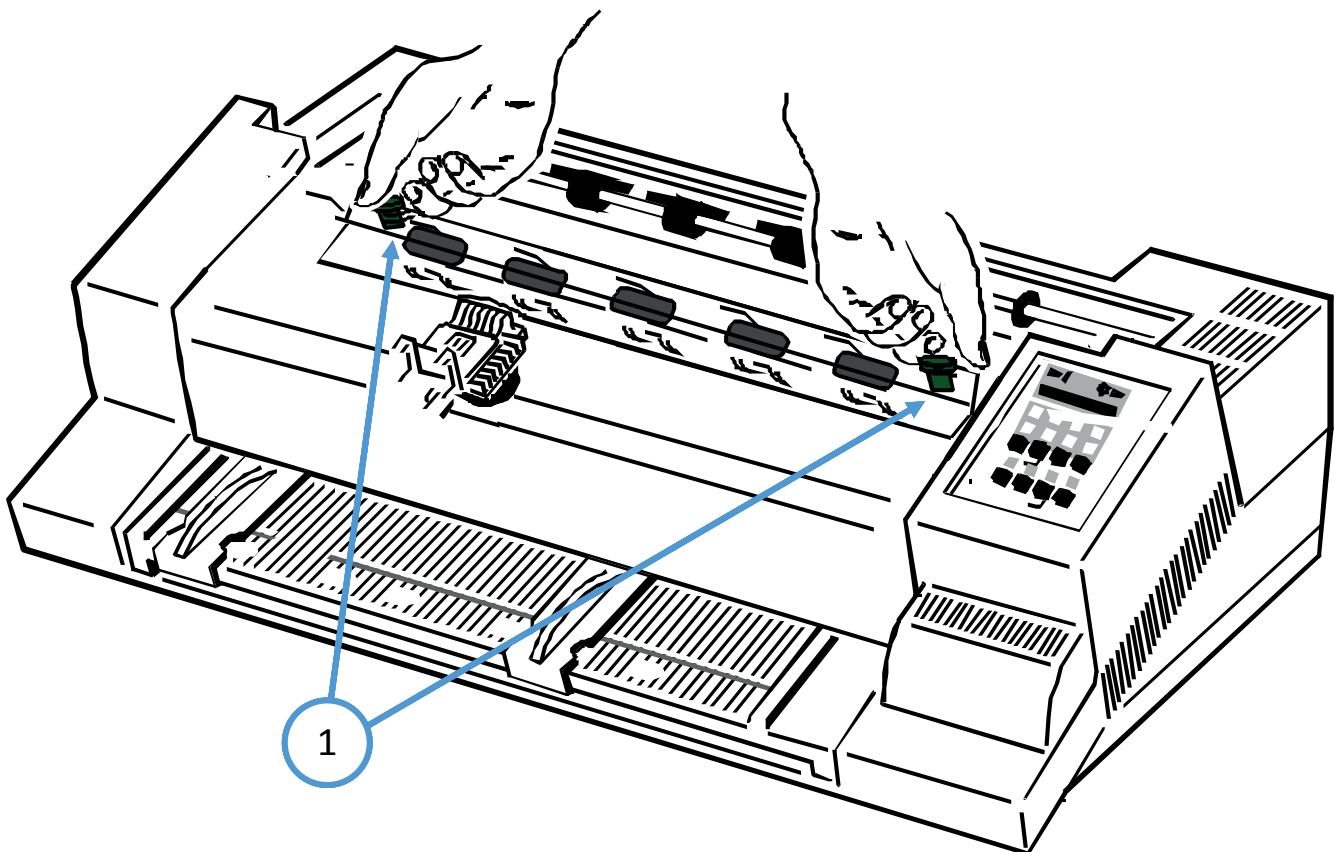

Part: Carriage 404/405

Part No: 5112 292 5499X
 Order No: 8707 901 00001
 FSI: 5112 991 17942

Steps: Remove Part

- Disconnect mains cable
- Remove all encasing parts (see Part: Housing)
- Remove the encoder stripe (see Part: Encoder Stripe)
- Remove the cable print head from the print head carriage (see Print Head Cable)
- Remove the print head (see Print Head)
- Remove Paper path selection lever (3)
- Remove the horizontal motor (see Part H-Motor)
- Remove the tractor gear (see Part Tractor Gear)
- Remove the two screws (2) and the upper rail (1)
- Release springs (5), and remove lever (4) including spring
- Remove the screws (6) from safty clip (7) and push the shaft (9) including the plastic segment (10) out towards the right hand side of the chassis.
- Remove carriage (8) by slide out from axis (9)

Note: The plastic segment (10) cannot be removed Slide the carriage (9) out of the guide rail

REASSEMBLING

- Execute the REMOVAL procedure in reverse sequence

Note: Engage the plastic segment in that way, that the guide rail (13) with the marker (12) aligns with the marker (11) on the AGC gear

- see also picture next page.

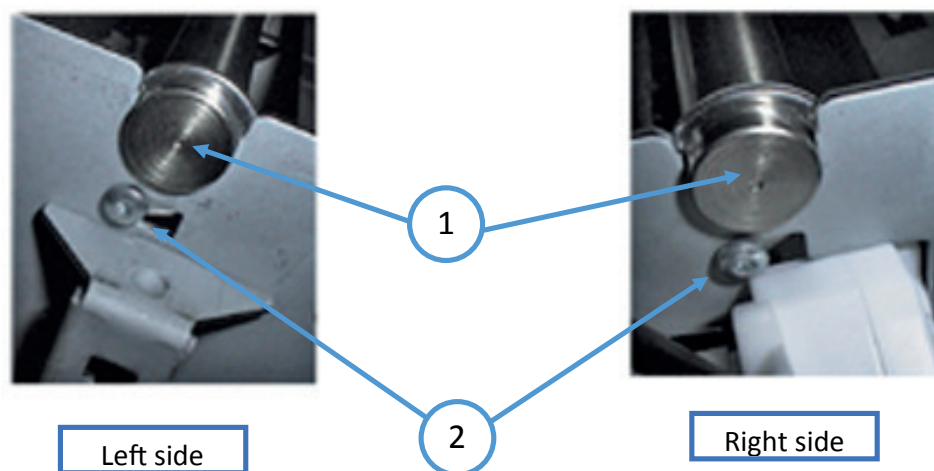

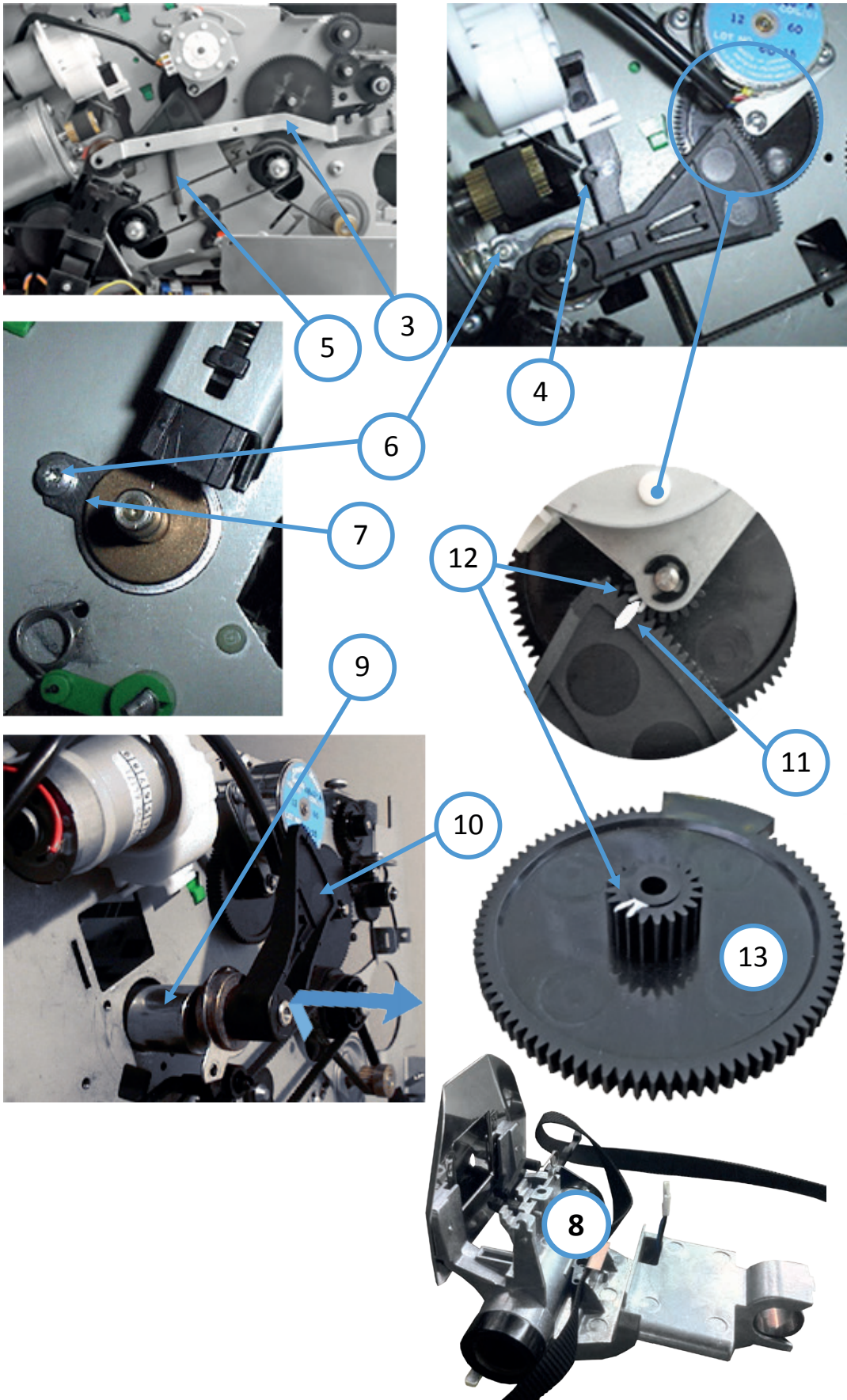

Part: Tractor Gear

Part No: 5112 292 3803X

Order No: 5322 522 10432

FSI: 5112 991 10603

Steps: Remove Part

- Disconnect mains cable
- Remove all encasing parts (see Part: Housing)
- The paper path for output must be set to tractor. By moving the carriage to the uppermost right position the paper path will be changed (an audible „click“)
- The axle (1) must be turned to the position as shown in Detail left side by turning on the mini pitch belt (7) in clockwise direction
- Remove all cables from the cable guide
- Remove the three screws (3) and Remove the Tractor Gear

REASSEMBLING

- Execute the REMOVAL procedure in reverse sequence

Note: Before the new can be mounted, turn the gear wheel (4) in such a way that the bold (5) reaches the uppermost position (Detail right side). Observe that the cable installation is correct

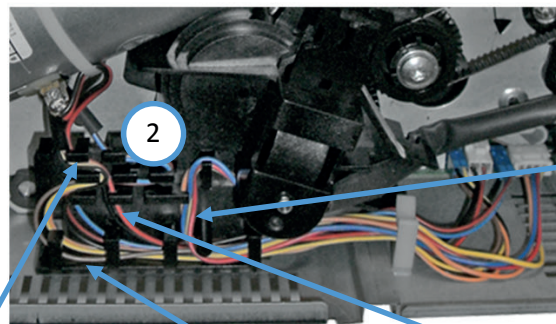
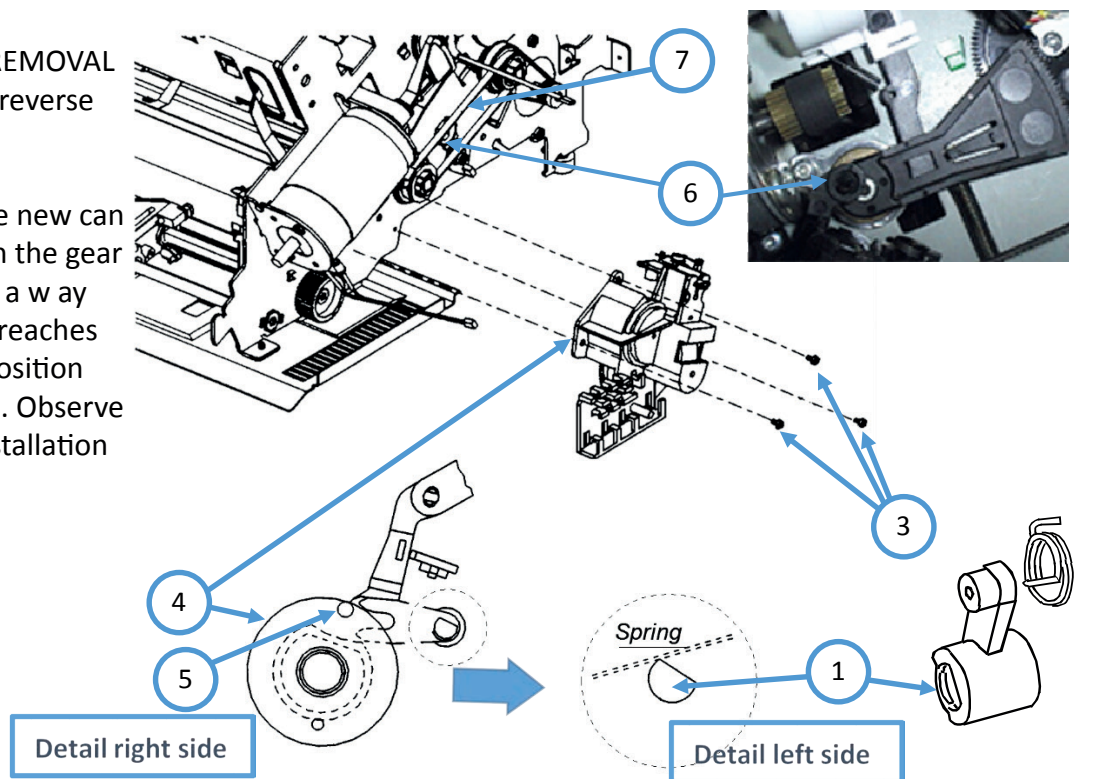

Horizontal Motor Cable

Stepping Motor
7.5 DEG Cable

Ribbon Gear Cable

Stepping Motor
1.8 DEG Cable

Part: Kit ASF Lever 2

Part No.: 5112 292 6875x

Order No.: 5322 310 10667

FSI: 5112 991 15071

Steps: Remove Part

REMOVAL of the Force Adjustment Levers (Figure 2)

- Remove the ASF-Cassette from the printer and Remove any paper loaded, and the paper support (if mounted).
- Remove the lever-side cover of the ASF Cassette by releasing of the four snap locks (No. 1 - 4 in figure 1). Use a flat screw driver to do so and keep the sequence of figure 1.
- Remove the circlip (No. 4 in figure 2) of the lever bar.
- Slide out the bar to the direction of the connector and snap the lever out of the encasing.

REASSEMBLING of the Force Adjustment Levers (Figure 2)

- Assemble the three levers together (figure 3). Lever 2 (upper paper release) onto lever 1 (paper pressure lever), and lever 3 (lower paper release) onto lever 2. Observe that the little plug of lever 2 is fitted in the hole provided in lever 3.
- Execute now the REMOVAL procedure in reverse sequence.

REMOVAL of the Locking Levers (Figure 5)

- Remove the ASF-Cassette from the printer and Remove any paper loaded, and the paper support (if mounted).
- Remove both side covers of the ASF Cassette by releasing of each snap locks (No. 1 - 4 in figure 1).
- Slide out the bar to the direction of the connector and release both paper guides to exchange the locking levers.

REASSEMBLING of the Locking Lever (Figure 5)

- Insert the left and right locking lever into the paper guides.
- Push the bar through the locking levers, the paper guides, and the support springs underneath the paper guides. Take care, that all parts are properly adjusted.
- Execute now the REMO VAL procedure in reverse sequence.

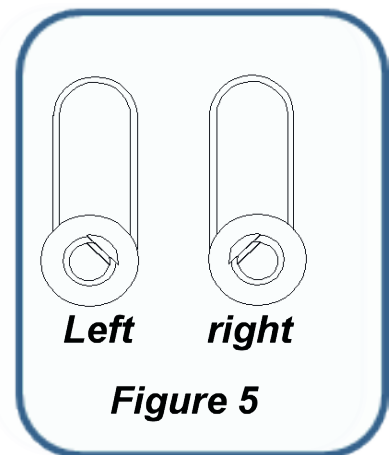
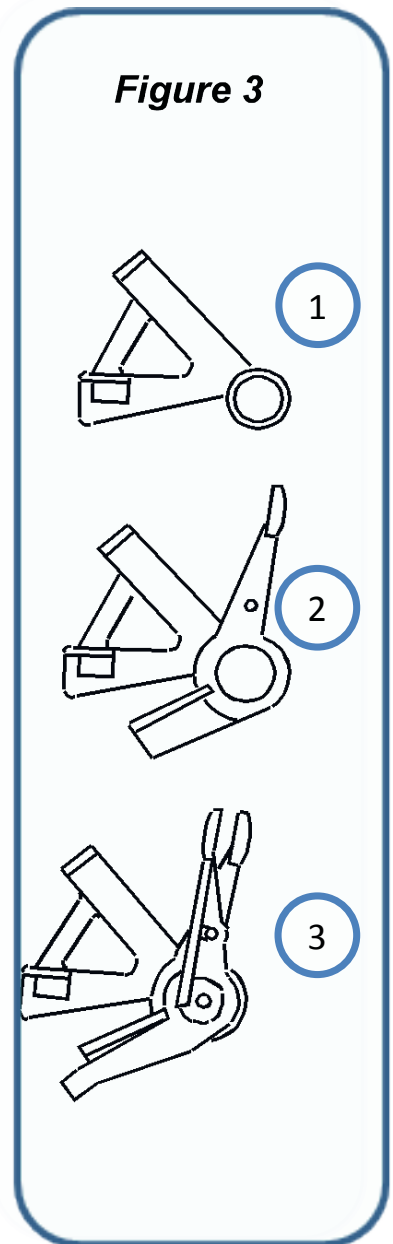
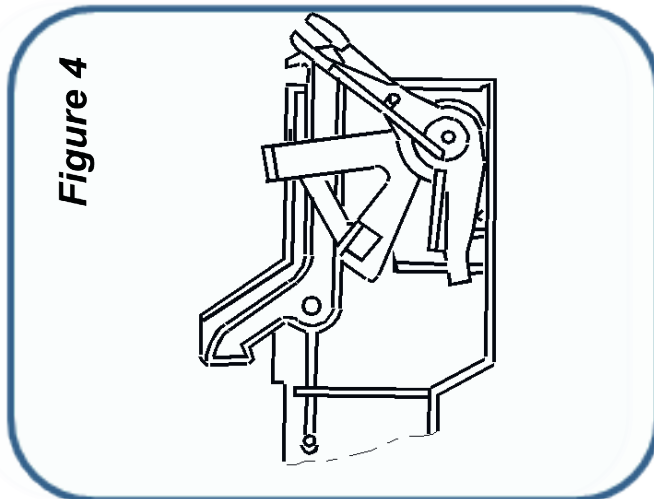
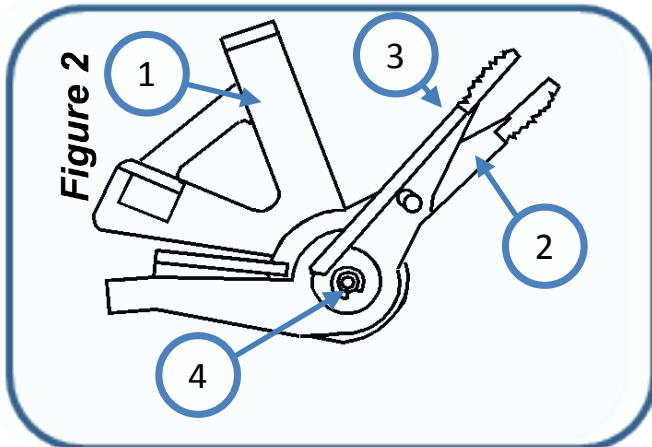
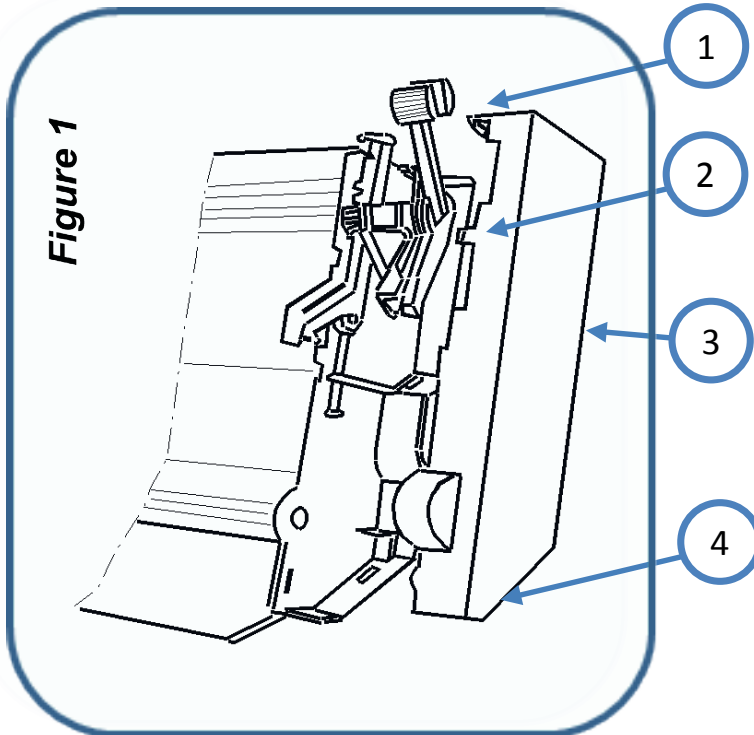

Part: Kit Spring D-Axis

Part No.:5112 292 3839x
Order No.: 5322 446 92441
FSI: 5112 991 10526

Steps: Remove Part

- Disconnect mains cable
- Open top cover
- Remove lever (1) from D-axis (the plastic snap-in will be destroyed)
- Remove the torsion spring (2)

REASSEMBLING

- Insert the new spring and grease the hole in the engine plate and the surface of the spring gliding on the plate
- Insert the lever (1) delivered with the spring until the snap-in
- Greased with Molycode DX or a similar product
- Execute the REMOVAL procedure in reverse sequence

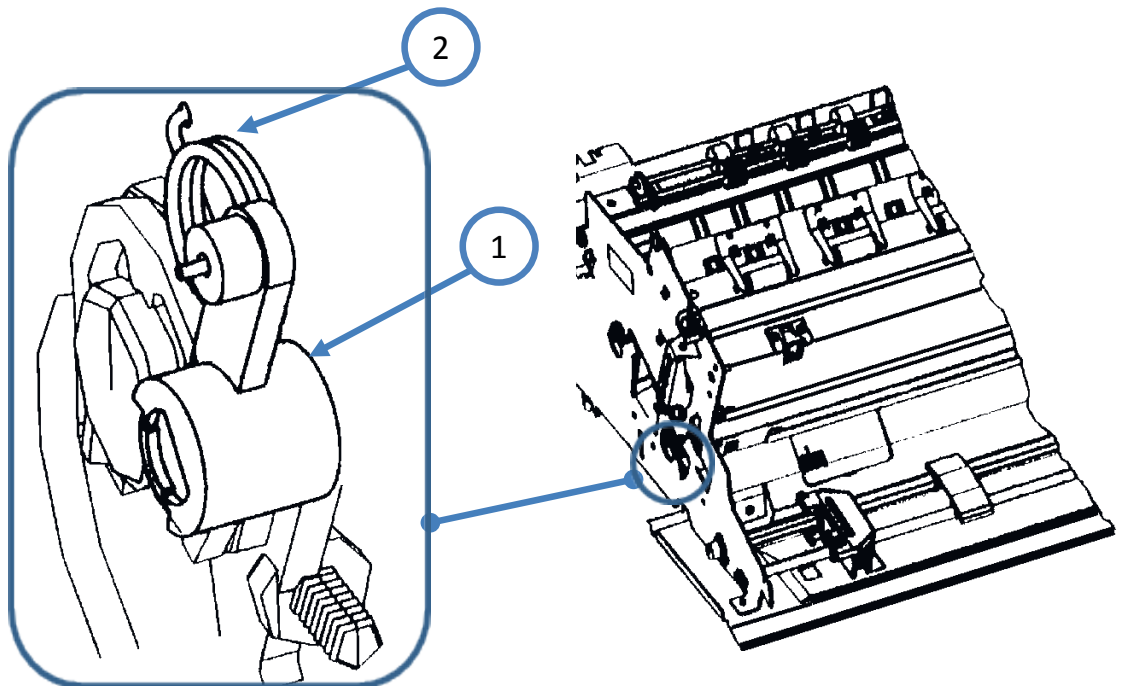

Grassed with Molycode DX
or a similar product

Part: Kit Screws and Springs

Part No.: 5112 292 3849x
 Order No.: 5322 310 31627

- | | |
|------------------------------------|---------------------------------|
| 1 Spring 0.6x4x23 ST F. Paper Run | 6 Spring Print Head Shifter |
| 2 Spring 0.3x4.5x20 ST Ribbon Gear | 7 Spring Paper Stacker Elements |
| 3 Spring Carriage Axis | 8 Torsion Spring D Shaped Axis |
| 4 Spring Carriage Bearing | |
| 5 Spring Encoder Cable | |

Location of springs

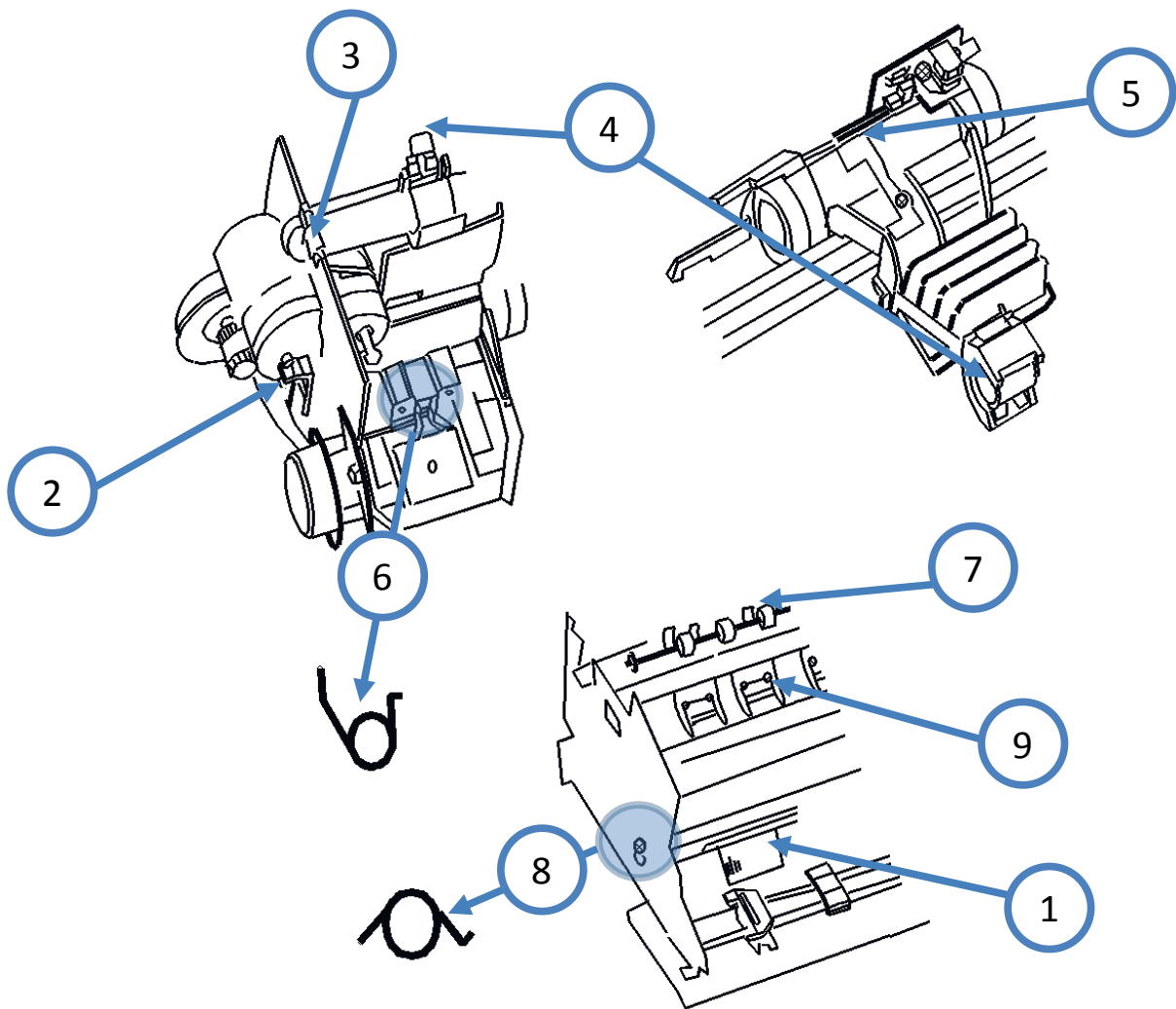

Part: Kit Screws and Springs

Part No.: 5112 292 3849x
Order No.: 5322 310 31627

- 9 Spring Tractor Exit
- 10 Spring Manual Front Insertion
- 11 Cable clip
- 12 Springs for Print Head Fixation (only older printers)
- 13 Holder right/left (green)
- 14 Bearing Platen (green)

Location of springs

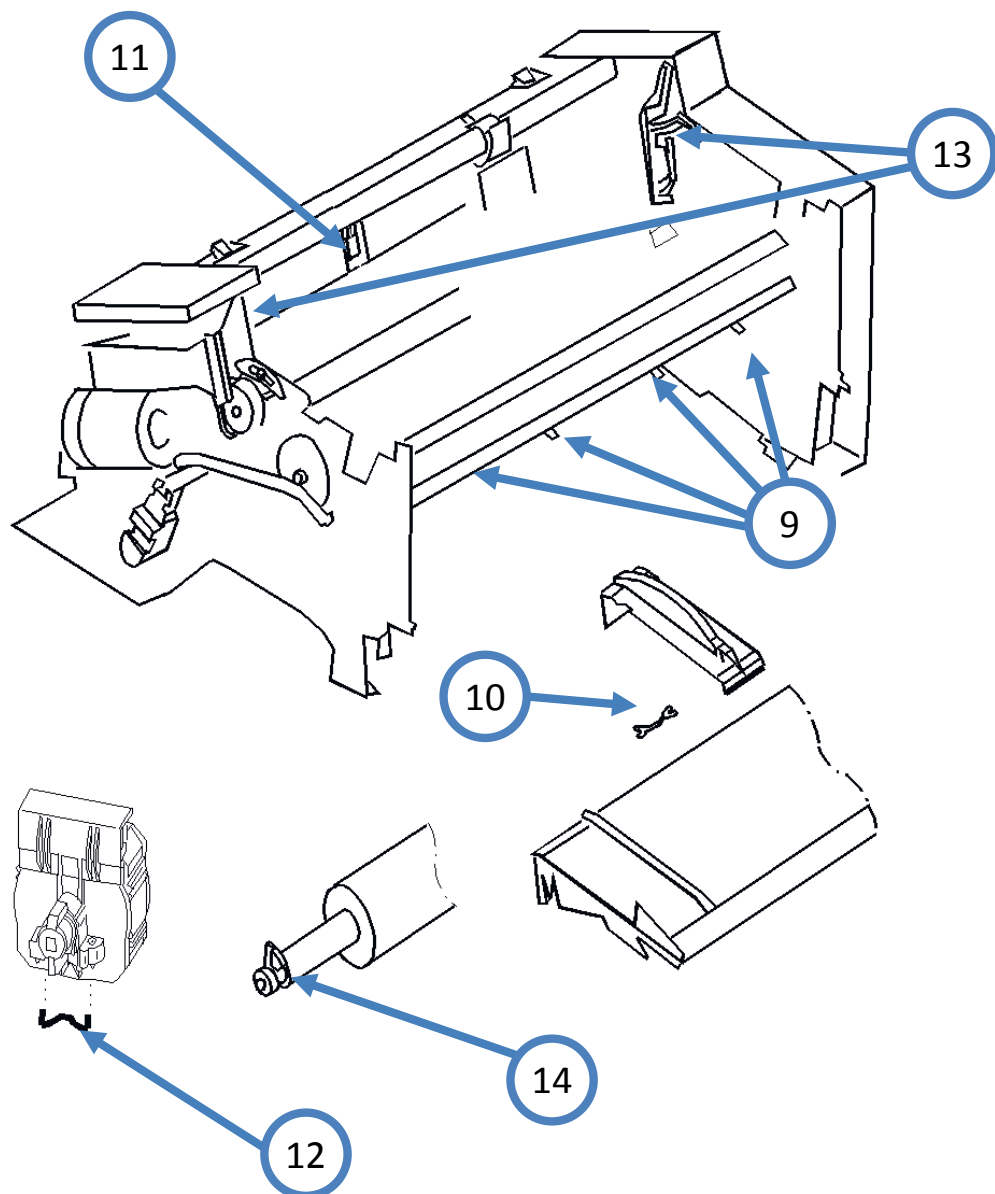

Part: Sep Lever ASF A2

Part No: 5112 292 6763x

Order Na 8707 240 99029

FSI: 5112 991 16781

To Remove the Bar (5) including the Pick-up Rolls ASF A2 and Lever ASFA2 (6)

- Remove the ASF cassette (1) from the printer by drawing back the release lever (2), releasing the mounting lugs.
- Remove the small access cover (3) by squeezing it together as shown.
- Pull back the retainers (4) as shown and lift up the bar (5).
- Pull the bar (5) out of the cassette.
- Remove the old Lever ASF 2 (6).

To install the Lever ASF A2 (6)

- Insert the new Lever ASF 2 (6), ensuring that the Lever ASF 2
- (6) is positioned so that the lower part of the lever mate with the slots (7) in the paper sleeves.
- Carefully snap the bar (5) into its mounting and fit the small access cover (3).
- Insert the free end of the bar (5) into its mounting, ensuring that each roller flange is positioned so that they mate with the slots (8) in the paper sleeves.

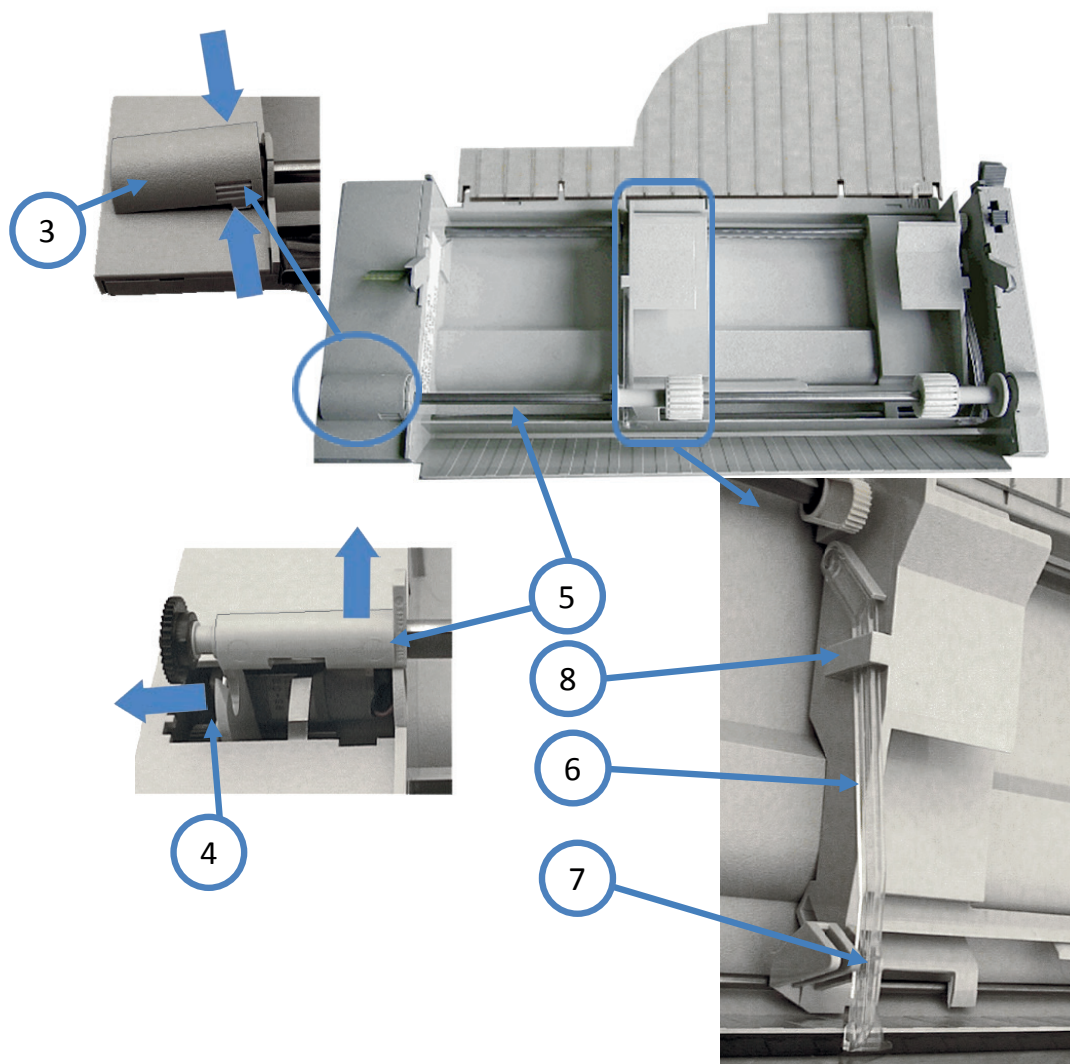

7. Wearing Parts

This chapter describes the removal procedures which are necessary for proper handling of the wearing parts of the printer.

Note: All removal procedures consists of several steps indicated with a:

To show preparation and to indicate the main removal steps.

In terms of preventive actions for keeping the printer running, following operation for the life time of wearing parts is given:

- Ribbon Cartridge: 16 Mio characters (draft quality)
- Print Head: > 350,000 pages
- Platen Assay: > 800,000 pages
- Pick up Rolls: > 200,000 pages
- Kit V-Transport: > 300,000 pages
- Kit Cont. Forms Exit: > 300,000 pages
- Paper Guide 4: > 300,000 pages
- Fan Fold Printer Recommendation for cleaning: Transport Rolls, Platen Assy, and Pick up Rolls every 50,000 Pages

Note: the Page Counter (PGCNT) in the PRINT-TEST 3 will give you information about actual number of printed pages. See sample next page.

CONFIGURATION

FW	20815776	F-D	0.2	F-X	0.3	PM	00-013665-0
NFQ	1500	DSF	100	NLSF	100	LSF	100
GSF	80	NFT	270	TNA1	230	TNA2	260
TNA3	260	CAC	2.60	NDLC	2.2	PGC	46
PGCNT	143299	SBP	36				

C031 ISO 8859/1	C032 ISO 8859/15	C034 ISO 8859/5
C032 ISO 8859/9	C061 IBM SET 1	C062 IBM SET 2
C063 IBM CODE PAGE	C071 EPSON EXT. GCT	C100 CODE PAGE EE
C101 CODE PAGE EE2	C912 GREEK CHR. SET	C069 ALL ICT TABLE
C091 BARCODE		
DATA	ROMAN NLQ	ROMAN LQ
SANS SERIF NLQ	SANS SERIF LQ	COURIER NLQ
COURIER LQ	PRESTIGE NLQ	PRESTIGE LQ
SCRIPT NLQ	SCRIPT LQ	OCR B LQ
OCR A LQ	ORATOR-C NLQ	ORATOR-C LQ
ORATOR NLQ	ORATOR LQ	DATA LARGE

CHARACTER SET : EPSON EXT. GCT 1: U.S.A.
ect.....

Part: Print Head PP40x-2

Part No: 5112 293 0326X

Order No: 8707 251 90501

FSI: 5112 991 10379

The platen need to be replaced after approximatively 800,000 pages compare page counter „PGCNT“ in the printer test („TEST 3“ - „HW-AUSBAU“).

Steps: Remove Part

- Turn on the printer, open the top cover, and lift it up.
 - The print head moves to the position opposite the green insertion aid (2) over the oval sheet metal cutout.
 - Switch the printer off.
 - Remove Stacker (1), Top cover (2) and the ribbon cassette (3).
 - Disconnect the printhead cable (4) by pulling back the retaining clip (8)
 - Using the supplied tool (7) remove the two fixing screws (6) of the printhead. The enclosed plastic sleeve (6) is to be used as an extension for the Allen (9) key.
 - Pull the print head (1) out of the printer.
- **see also picture next page.**

REASSEMBLING

- Execute the REMOVAL procedure in reverse sequence
- Hold the print head (5) in its mounting position and press it against its stop in direction of the platen. The two noses (11) of the adjustment guide (10) support this procedure. Fix crews (6)

Attention: After replacing the print head, run the MENU-function **AGC ADJUST** without any paper inserted into the printer to set new parameters for AGC.

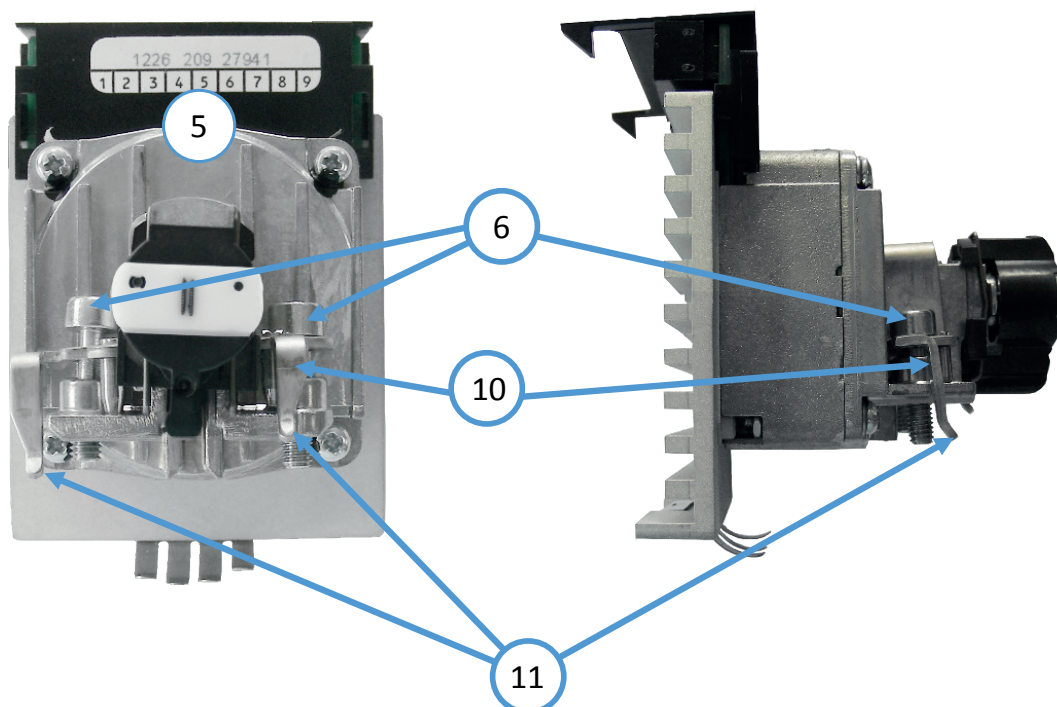

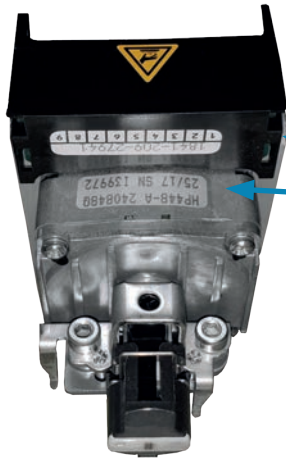

The meaning of the both labels is slightly differ.
In case of a warranty claim both information are important

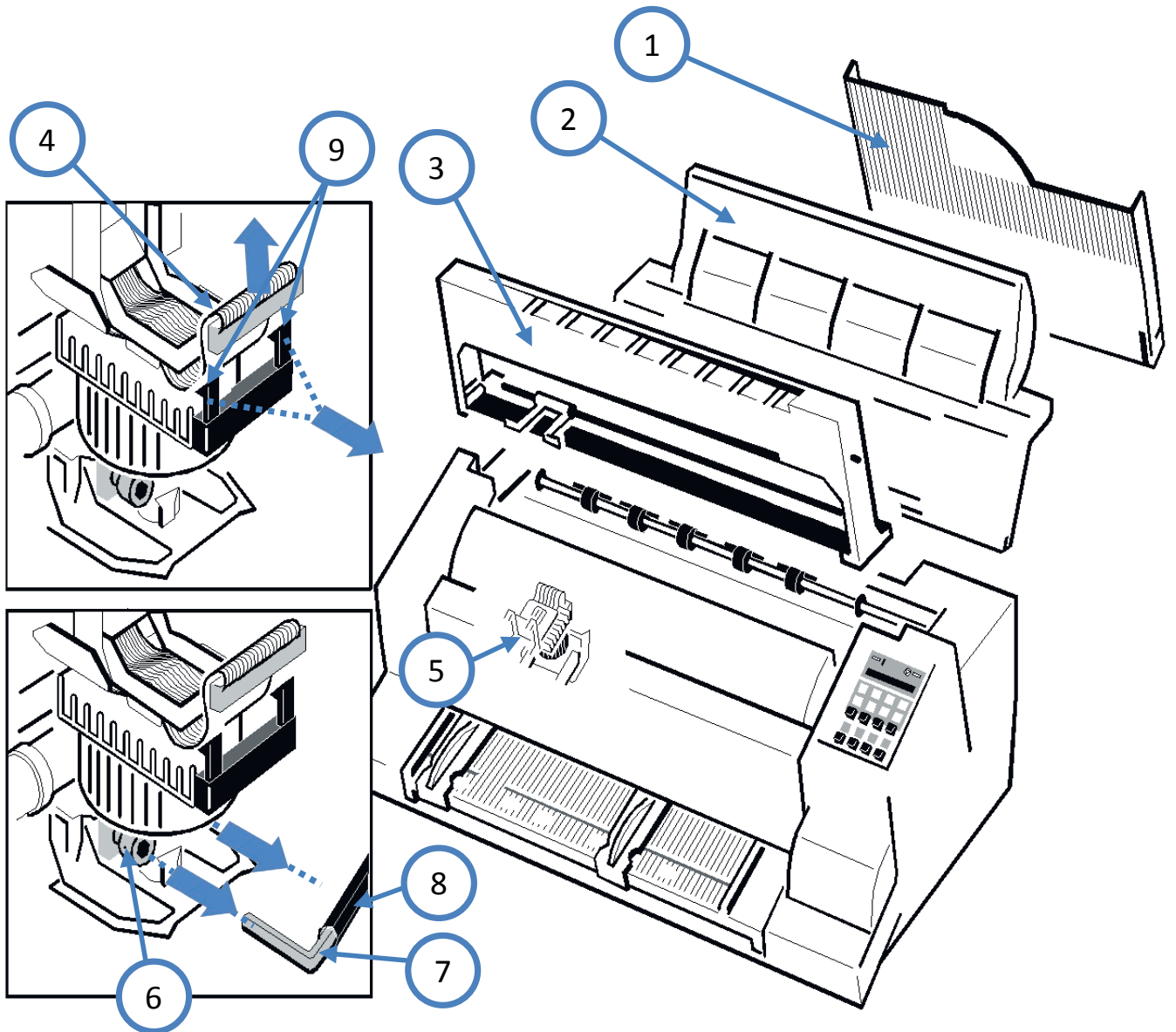

Part: Platen Assy

Part No.: 5112 292 3801x

Order No.: 8707 240 90802

FSI: 5112 991 10352

A change of the platen roller may become necessary after about 800,000 pages (compare page counter „PGCNT“ in the printer test „TEST 3“ - „HW-AUSBAU“).

Steps: Remove Part

- Power off printer
- Lift and Remove the output stacker. Open the top cover and remove it upwards.
- Remove the Ribbon cassette.
- Position the print head to the very right (3).
- Release the plastic platen clamp (2) on the left platen mounting.
- Move platen (2) approximately 10 mm to the left, lift the left end of the platen free of its mounting and withdraw the platen from the right mounting.
- Lift the platen to the left underneath the print head and take the platen out.

REASSEMBLING

- Execute the REMOVAL procedure in reverse sequence

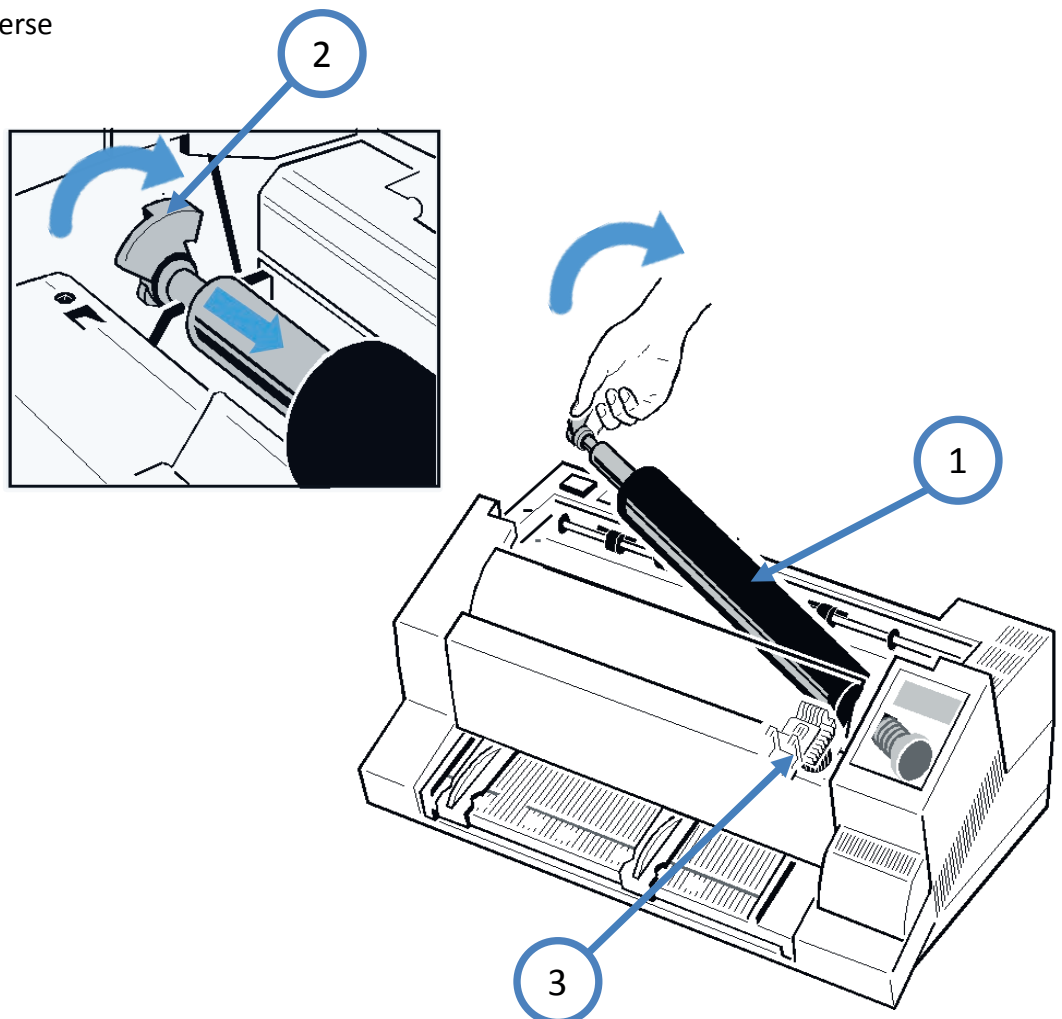

Part: Pick up rollers

Part No.: 5112 292 4100x

Order No.: 8707 240 90821

FSI: 5112 991 16771

A change of the pick up roller may become necessary after about 200,000 pages (compare page counter „PGCNT“ in the printer test „TEST 3“ - „HW-AUSBAU“).

Steps: Remove Part

- Remove the ASF cassette (1) from the printer by drawing back the release lever (2), releasing the mounting lugs.
- Remove the small access cover (5) by squeezing it together as shown.
- Pull back the retainers (7) as shown and lift up the axis (4) and pull it out of the Gaps (6) and left side cassette
- Slide the pick-up rollers (3) form the axis.

REASSEMBLING

- Execute the REMOVAL procedure in reverse sequence

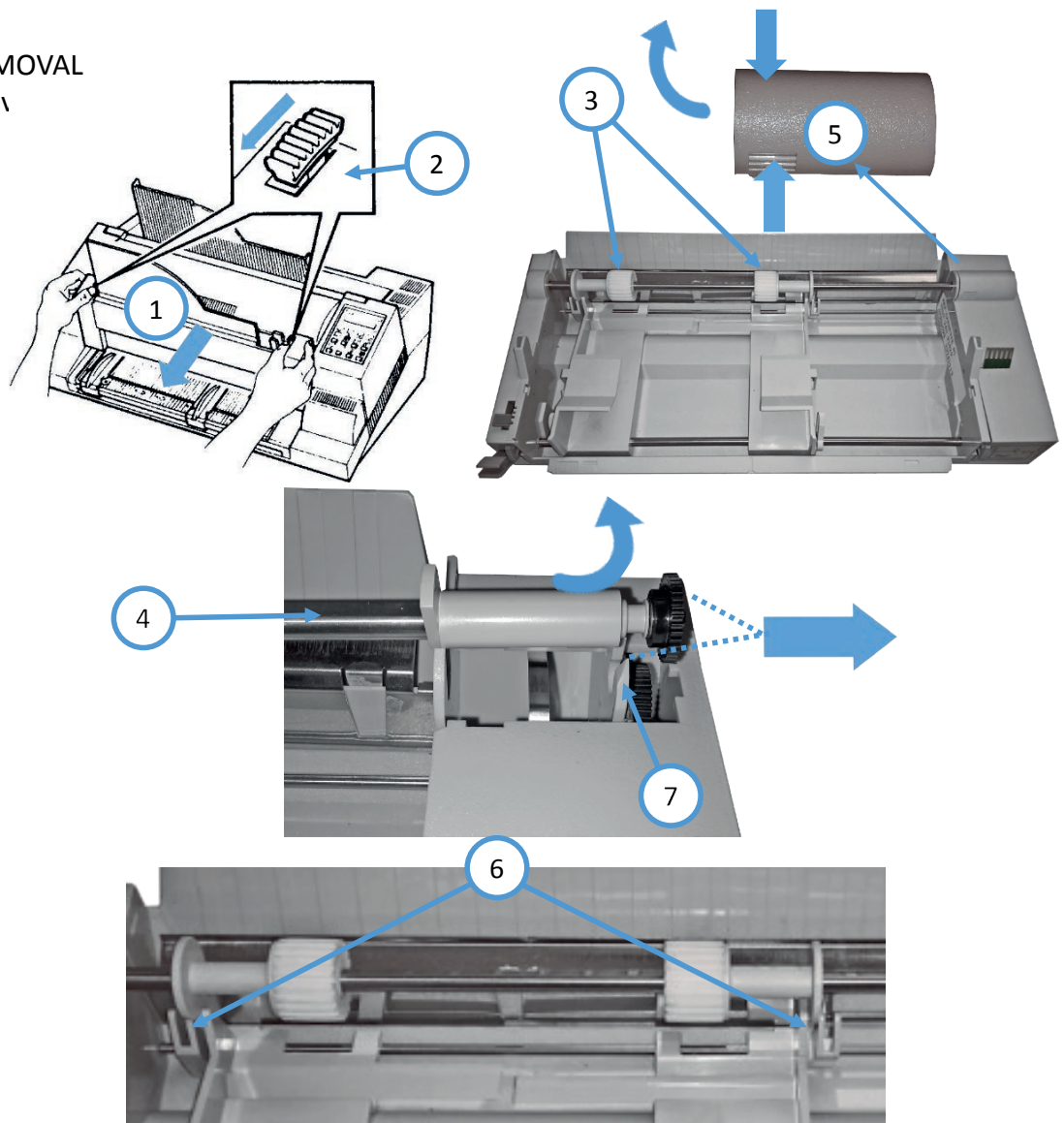

8. Spare Parts Cross Reference List

Part	Order Number
Power Switch 40A	5322 276 12685
Kit ASF-Lever 2	5322 310 10667
Kit V-Transport 404	5322 310 11123
Kit Tractor 2	5322 310 11124
Kit Left Stopper	5322 310 11261
Kit Belt Pulley 3 404/5	5322 310 11313
Kit H-Drive Belt	5322 310 31374
Kit V-Transport	5322 310 31375
Kit Cont. Forms Exit	5322 310 31376
Kit Spring D-Axis	5322 310 32088
Kit Lubrication Felt	5322 310 32108
Kit Pressure Rolls	5322 310 32109
Belt Stepper	5322 358 20369
Belt Form Feed	5322 358 20391
Front Cover 404	5322 442 01203
Top Cover 404	5322 442 01204
Housing 404/5	5322 447 80485
Top Cover 405	5322 447 80486
Front Insertion 405	5322 447 80487
Front Cover 405	5322 447 80637
Stacker Support 405	5322 447 80638
Encoder Strip 2	5322 466 11114
Paper Guide 4 405	5322 466 11766
Paper Guide 4 404	5322 466 11768
Protection Shield	5322 466 92441
Tractor Gear	5322 522 10432
Kit Cont. Exit Gear	5322 522 10746
Carriage	5322 693 22606
Stacker Elements	5322 693 34073

Part	Order Number
Platen Assy	8707 240 90802
Pick-up Rolls ASF A1, B1, C1	8707 240 90821
ASF-Cassette A1	8707 240 91821
ASF-Cassette C1	8707 240 91824
ASF-Cassette B1	8707 240 91829
Printer Stand PP 404 / 5	8707 241 90502
Stacker Option	8707 340 90513
Print Head PP40x	8707 251 90501
Kit Tractor Flap re.	8707 901 00011
Paper Sensor-R	8707 901 00013
Operator Panel 40B-R	8707 901 00015
PSU2 PP405 230V-R	8707 901 00028
DEV2 PP404/5	8707 901 00029
Print Head Cable 404/5	8707 901 00030
Print H-Encoder	8707 901 00031
H-Motor	8707 901 00032
Ribbon Gear	8707 901 00033
Stepper Motor 7.5 DEG	8707 901 00034
Stepper Motor 1.8 DEG	8707 901 00035
Kit Carriage Axles	8707 901 00056
Kit Key Map OP	8707 901 00057
Ribbon Cassette Fabric Black S/RC 78	8709 002 37801
Ribbon Cassette Fabric Black S/RC 82 white lable	8708 002 37801
Cover Open Clip	8709 010 93421